

INTERNATIONAL STANDARD

NORME INTERNATIONALE

**Household and similar electrical appliances – Safety –
Part 2-9: Particular requirements for grills, toasters and similar portable cooking
appliances**

**Appareils électrodomestiques et analogues – Sécurité –
Partie 2-9: Exigences particulières pour les grills, les grille-pain et les appareils
de cuisson mobiles analogues**



THIS PUBLICATION IS COPYRIGHT PROTECTED
Copyright © 2019 IEC, Geneva, Switzerland

All rights reserved. Unless otherwise specified, no part of this publication may be reproduced or utilized in any form or by any means, electronic or mechanical, including photocopying and microfilm, without permission in writing from either IEC or IEC's member National Committee in the country of the requester. If you have any questions about IEC copyright or have an enquiry about obtaining additional rights to this publication, please contact the address below or your local IEC member National Committee for further information.

Droits de reproduction réservés. Sauf indication contraire, aucune partie de cette publication ne peut être reproduite ni utilisée sous quelque forme que ce soit et par aucun procédé, électronique ou mécanique, y compris la photocopie et les microfilms, sans l'accord écrit de l'IEC ou du Comité national de l'IEC du pays du demandeur. Si vous avez des questions sur le copyright de l'IEC ou si vous désirez obtenir des droits supplémentaires sur cette publication, utilisez les coordonnées ci-après ou contactez le Comité national de l'IEC de votre pays de résidence.

IEC Central Office
3, rue de Varembe
CH-1211 Geneva 20
Switzerland

Tel.: +41 22 919 02 11
info@iec.ch
www.iec.ch

About the IEC

The International Electrotechnical Commission (IEC) is the leading global organization that prepares and publishes International Standards for all electrical, electronic and related technologies.

About IEC publications

The technical content of IEC publications is kept under constant review by the IEC. Please make sure that you have the latest edition, a corrigendum or an amendment might have been published.

IEC publications search - webstore.iec.ch/advsearchform

The advanced search enables to find IEC publications by a variety of criteria (reference number, text, technical committee,...). It also gives information on projects, replaced and withdrawn publications.

IEC Just Published - webstore.iec.ch/justpublished

Stay up to date on all new IEC publications. Just Published details all new publications released. Available online and once a month by email.

IEC Customer Service Centre - webstore.iec.ch/csc

If you wish to give us your feedback on this publication or need further assistance, please contact the Customer Service Centre: sales@iec.ch.

Electropedia - www.electropedia.org

The world's leading online dictionary on electrotechnology, containing more than 22 000 terminological entries in English and French, with equivalent terms in 16 additional languages. Also known as the International Electrotechnical Vocabulary (IEV) online.

IEC Glossary - std.iec.ch/glossary

67 000 electrotechnical terminology entries in English and French extracted from the Terms and Definitions clause of IEC publications issued since 2002. Some entries have been collected from earlier publications of IEC TC 37, 77, 86 and CISPR.

A propos de l'IEC

La Commission Electrotechnique Internationale (IEC) est la première organisation mondiale qui élabore et publie des Normes internationales pour tout ce qui a trait à l'électricité, à l'électronique et aux technologies apparentées.

A propos des publications IEC

Le contenu technique des publications IEC est constamment revu. Veuillez vous assurer que vous possédez l'édition la plus récente, un corrigendum ou amendement peut avoir été publié.

Recherche de publications IEC - webstore.iec.ch/advsearchform

La recherche avancée permet de trouver des publications IEC en utilisant différents critères (numéro de référence, texte, comité d'études,...). Elle donne aussi des informations sur les projets et les publications remplacées ou retirées.

IEC Just Published - webstore.iec.ch/justpublished

Restez informé sur les nouvelles publications IEC. Just Published détaille les nouvelles publications parues. Disponible en ligne et une fois par mois par email.

Service Clients - webstore.iec.ch/csc

Si vous désirez nous donner des commentaires sur cette publication ou si vous avez des questions contactez-nous: sales@iec.ch.

Electropedia - www.electropedia.org

Le premier dictionnaire d'électrotechnologie en ligne au monde, avec plus de 22 000 articles terminologiques en anglais et en français, ainsi que les termes équivalents dans 16 langues additionnelles. Egalement appelé Vocabulaire Electrotechnique International (IEV) en ligne.

Glossaire IEC - std.iec.ch/glossary

67 000 entrées terminologiques électrotechniques, en anglais et en français, extraites des articles Termes et Définitions des publications IEC parues depuis 2002. Plus certaines entrées antérieures extraites des publications des CE 37, 77, 86 et CISPR de l'IEC.

INTERNATIONAL STANDARD

NORME INTERNATIONALE

**Household and similar electrical appliances – Safety –
Part 2-9: Particular requirements for grills, toasters and similar portable cooking
appliances**

**Appareils électrodomestiques et analogues – Sécurité –
Partie 2-9: Exigences particulières pour les grils, les grille-pain et les appareils
de cuisson mobiles analogues**

INTERNATIONAL
ELECTROTECHNICAL
COMMISSION

COMMISSION
ELECTROTECHNIQUE
INTERNATIONALE

CONTENTS

FOREWORD.....	4
INTRODUCTION.....	7
1 Scope.....	8
2 Normative references	9
3 Terms and definitions	9
4 General requirement.....	14
5 General conditions for the tests	14
6 Classification.....	14
7 Marking and instructions.....	14
8 Protection against access to live parts.....	16
9 Starting of motor-operated appliances	17
10 Power input and current.....	17
11 Heating.....	17
12 Void.....	21
13 Leakage current and electric strength at operating temperature.....	21
14 Transient overvoltages	22
15 Moisture resistance	22
16 Leakage current and electric strength.....	23
17 Overload protection of transformers and associated circuits	24
18 Endurance.....	24
19 Abnormal operation	24
20 Stability and mechanical hazards.....	26
21 Mechanical strength	26
22 Construction	27
23 Internal wiring.....	30
24 Components	30
25 Supply connection and external flexible cords	31
26 Terminals for external conductors.....	32
27 Provision for earthing	32
28 Screws and connections	32
29 Clearances, creepage distances and solid insulation	32
30 Resistance to heat and fire	32
31 Resistance to rusting	33
32 Radiation, toxicity and similar hazards.....	33
Annexes	40
Annex C (normative) Ageing test on motors.....	41
Annex R (normative) Software evaluation	42
Bibliography.....	43
Figure 101 – Examples of appliances.....	35

Figure 103 – Vessel for testing hotplates	37
Figure 104 – Vessel for testing induction hotplates	37
Figure 105 – Probe for measuring surface temperatures	38
Figure 106 – Front view of appliance with identification of excluded areas	39
Table 101 – Quantity of liquid in the vessel	10
Table 102 – Temperature rises for external surfaces	19

INTERNATIONAL ELECTROTECHNICAL COMMISSION

HOUSEHOLD AND SIMILAR ELECTRICAL APPLIANCES – SAFETY –

Part 2-9: Particular requirements for grills, toasters and similar portable cooking appliances

FOREWORD

- 1) The International Electrotechnical Commission (IEC) is a worldwide organization for standardization comprising all national electrotechnical committees (IEC National Committees). The object of IEC is to promote international co-operation on all questions concerning standardization in the electrical and electronic fields. To this end and in addition to other activities, IEC publishes International Standards, Technical Specifications, Technical Reports, Publicly Available Specifications (PAS) and Guides (hereafter referred to as "IEC Publication(s)"). Their preparation is entrusted to technical committees; any IEC National Committee interested in the subject dealt with may participate in this preparatory work. International, governmental and non-governmental organizations liaising with the IEC also participate in this preparation. IEC collaborates closely with the International Organization for Standardization (ISO) in accordance with conditions determined by agreement between the two organizations.
- 2) The formal decisions or agreements of IEC on technical matters express, as nearly as possible, an international consensus of opinion on the relevant subjects since each technical committee has representation from all interested IEC National Committees.
- 3) IEC Publications have the form of recommendations for international use and are accepted by IEC National Committees in that sense. While all reasonable efforts are made to ensure that the technical content of IEC Publications is accurate, IEC cannot be held responsible for the way in which they are used or for any misinterpretation by any end user.
- 4) In order to promote international uniformity, IEC National Committees undertake to apply IEC Publications transparently to the maximum extent possible in their national and regional publications. Any divergence between any IEC Publication and the corresponding national or regional publication shall be clearly indicated in the latter.
- 5) IEC itself does not provide any attestation of conformity. Independent certification bodies provide conformity assessment services and, in some areas, access to IEC marks of conformity. IEC is not responsible for any services carried out by independent certification bodies.
- 6) All users should ensure that they have the latest edition of this publication.
- 7) No liability shall attach to IEC or its directors, employees, servants or agents including individual experts and members of its technical committees and IEC National Committees for any personal injury, property damage or other damage of any nature whatsoever, whether direct or indirect, or for costs (including legal fees) and expenses arising out of the publication, use of, or reliance upon, this IEC Publication or any other IEC Publications.
- 8) Attention is drawn to the Normative references cited in this publication. Use of the referenced publications is indispensable for the correct application of this publication.
- 9) Attention is drawn to the possibility that some of the elements of this IEC Publication may be the subject of patent rights. IEC shall not be held responsible for identifying any or all such patent rights.

International Standard IEC 60335-2-9 has been prepared by IEC technical committee 61: Safety of household and similar electrical appliances.

This seventh edition cancels and replaces the sixth edition published in 2008, Amendment 1: 2012 and Amendment 2:2016. This edition constitutes a technical revision.

This edition includes the following significant technical changes with respect to the previous edition:

- aligns the text with IEC 60335-1, Ed 5, and its Amendments 1 and 2;
- revises the abnormal tests for a toaster (19.11.2, 19.102).

The text of this International Standard is based on the following documents:

FDIS	Report on voting
61/5797/FDIS	61/5838/RVD

Full information on the voting for the approval of this International Standard can be found in the report on voting indicated in the above table.

This document has been drafted in accordance with the ISO/IEC Directives, Part 2.

A list of all parts in the IEC 60335 series, published under the general title *Household and similar electrical appliances – Safety*, can be found on the IEC website.

This part 2 is to be used in conjunction with the latest edition of IEC 60335-1 and its amendments. It was established on the basis of the fifth edition (2010) of that standard.

NOTE 1 When "Part 1" is mentioned in this standard, it refers to IEC 60335-1.

This part 2 supplements or modifies the corresponding clauses in IEC 60335-1, so as to convert that publication into the IEC standard: *Safety requirements for grills, toasters and similar portable cooking appliances*.

When a particular subclause of Part 1 is not mentioned in this part 2, that subclause applies as far as is reasonable. When this standard states "addition", "modification" or "replacement", the relevant text in Part 1 is to be adapted accordingly.

NOTE 2 The following numbering system is used:

- subclauses, tables and figures that are numbered starting from 101 are additional to those in Part 1;
- unless notes are in a new subclause or involve notes in Part 1, they are numbered starting from 101, including those in a replaced clause or subclause;
- additional annexes are lettered AA, BB, etc.

NOTE 3 The following print types are used:

- requirements: in roman type;
- test specifications: *in italic type*;
- notes: in small roman type.

Words in **bold** in the text are defined in Clause 3. When a definition concerns an adjective, the adjective and the associated noun are also in bold.

The committee has decided that the contents of this document will remain unchanged until the stability date indicated on the IEC website under "<http://webstore.iec.ch>" in the data related to the specific document. At this date, the document will be

- reconfirmed,
- withdrawn,
- replaced by a revised edition, or
- amended.

NOTE 4 The attention of National Committees is drawn to the fact that equipment manufacturers and testing organizations may need a transitional period following publication of a new, amended or revised IEC publication in which to make products in accordance with the new requirements and to equip themselves for conducting new or revised tests.

It is the recommendation of the committee that the content of this publication be adopted for implementation nationally not earlier than 12 months nor later than 36 months from the date of its publication.

The following differences exist in the countries indicated below:

- 3.1.9: Different loads and test methods are used (USA).
- 5.101: If the appliance incorporates a motor, the motor is tested at rated voltage (USA).
- 7.12: Identification of the connector is to be marked on the appliance (USA).
- 11.2: 9,5 mm thick plywood is used for the test corner (USA).
- 11.7: The test duration is based on the quantity of food (USA).
- 11.8: A temperature rise of 100 K is allowed for the wall of the test corner (USA).
- 11.101: There are no surface temperature limits on toasters having a metallic enclosure unless they are under cabinet or wall mounted, in which case it is allowed for the temperatures to reach 100 °C if a proper marking is provided (USA).
- 15.2: A different solution is used and the test is not carried out on ovens, hotplates or cookers (USA).
- 15.101: Appliances are immersed to the marked level only (USA).
- 19.2: A 300 mm deep simulated cabinet is located 400 mm above the countertop (USA).
- 19.2: The test is different. Additional tests are carried out on hotplates and cookers (USA):
- 19.101: Different test methods and numbers of cycles are used (USA).
- 19.102: A combustible cloth is placed above the toaster and the residual bread is left in place (USA).
- 19.104: Disks having different sizes are used (USA).
- 20.101: The test is not carried out (USA).
- 21.101: The test is different (USA).
- 22.105: The requirement is not applicable (USA).
- 22.108: The test is different (USA).
- 22.110: The test is different (USA).
- 22.111: The test is not carried out (USA).
- 22.112: The test is not carried out (USA).
- 24.1.3: The test is not carried out (USA).
- 24.101: The test is not carried out (USA).
- 25.7: The free length of the supply cord is specified; in some cases, it is 1,8 m to 2,1 m for appliances intended to be connected to fixed socket-outlets, while in others it is 0,6 m to 2,1 m for appliances normally used on a table or similar surface (USA).

INTRODUCTION

It has been assumed in the drafting of this International Standard that the execution of its provisions is entrusted to appropriately qualified and experienced persons.

This standard recognizes the internationally accepted level of protection against hazards such as electrical, mechanical, thermal, fire and radiation of appliances when operated as in normal use taking into account the manufacturer's instructions. It also covers abnormal situations that can be expected in practice and takes into account the way in which electromagnetic phenomena can affect the safe operation of appliances.

This standard takes into account the requirements of IEC 60364 as far as possible so that there is compatibility with the wiring rules when the appliance is connected to the supply mains. However, national wiring rules may differ.

If an appliance within the scope of this standard also incorporates functions that are covered by another part 2 of IEC 60335, the relevant part 2 is applied to each function separately, as far as is reasonable. If applicable, the influence of one function on the other is taken into account.

When a part 2 standard does not include additional requirements to cover hazards dealt with in Part 1, Part 1 applies.

NOTE 1 This means that the technical committees responsible for the part 2 standards have determined that it is not necessary to specify particular requirements for the appliance in question over and above the general requirements.

This standard is a product family standard dealing with the safety of appliances and takes precedence over horizontal and generic standards covering the same subject.

NOTE 2 Horizontal and generic standards covering a hazard are not applicable since they have been taken into consideration when developing the general and particular requirements for the IEC 60335 series of standards. For example, in the case of temperature requirements for surfaces on many appliances, generic standards, such as ISO 13732-1 for hot surfaces, are not applicable in addition to Part 1 or part 2 standards.

An appliance that complies with the text of this standard will not necessarily be considered to comply with the safety principles of the standard if, when examined and tested, it is found to have other features which impair the level of safety covered by these requirements.

An appliance employing materials or having forms of construction differing from those detailed in the requirements of this standard may be examined and tested according to the intent of the requirements and, if found to be substantially equivalent, may be considered to comply with the standard.

HOUSEHOLD AND SIMILAR ELECTRICAL APPLIANCES – SAFETY –

Part 2-9: Particular requirements for grills, toasters and similar portable cooking appliances

1 Scope

This clause of Part 1 is replaced by the following.

This International Standard deals with the safety of electric **portable appliances** for household and similar purposes that have a cooking function such as baking, roasting and grilling, their **rated voltage** being not more than 250 V.

NOTE 101 Examples of appliances that are within the scope of this standard are

- barbecues for indoor use;
- breadmakers;
- candy floss appliances;
- contact grills (griddles);
- cookers;
- food dehydrators;
- hotplates;
- induction wok hotplates;
- pop-corn makers;
- portable ovens;
- raclette grills;
- radiant grills;
- roasters;
- rotary grills;
- rotisseries;
- toasters;
- waffle irons;

Examples are illustrated in Figure 101.

Appliances intended for normal household and similar use and that may also be used by laymen in shops, in light industry and on farms, are within the scope of this standard. However, if the appliance is intended to be used professionally to process food for commercial consumption, the appliance is not considered to be for household and similar use only.

As far as is practicable, this standard deals with the common hazards presented by appliances that are encountered by all persons in and around the home. However, in general, it does not take into account

- persons (including children) whose
 - physical, sensory or mental capabilities; or
 - lack of experience and knowledgeprevents them from using the appliance safely without supervision or instruction;
- children playing with the appliance.

NOTE 102 Attention is drawn to the fact that

- for appliances intended to be used in vehicles or on board ships or aircraft, additional requirements could be necessary;
- in many countries, additional requirements are specified by the national health authorities, the national authorities responsible for the protection of labour and similar authorities.

NOTE 103 This standard does not apply to

- **stationary ovens** and **stationary grills** (IEC 60335-2-6);
- warming plates (IEC 60335-2-12);
- frying pans and deep fat fryers (IEC 60335-2-13);
- microwave ovens (IEC 60335-2-25);
- barbecues for outdoor use (IEC 60335-2-78);
- appliances intended to burn charcoal or similar combustible fuels;
- appliances intended for commercial catering;
- appliances intended to be used in locations where special conditions prevail, such as the presence of a corrosive or explosive atmosphere (dust, vapour or gas).

2 Normative references

This clause of part 1 is applicable except as follows.

Replacement:

IEC 60320-1:2015, *Appliance couplers for household and similar general purposes – Part 1: General requirements*

Addition:

IEC 60068-2-52, *Environmental testing – Part 2: Tests – Test Kb: Salt mist, cyclic (sodium chloride solution)*

IEC 60320-3, *Appliance couplers for household and similar general purposes – Part 3: Standard sheets and gauges*

IEC 60584-1, *Thermocouples – Part 1: EMF specifications and tolerances*

ISO 3864-1, *Graphical symbols – Safety colours and safety signs – Part 1: Design principles for safety signs and safety markings*

3 Terms and definitions

This clause of Part 1 is applicable except as follows.

3.1 Definitions relating to physical characteristics

Replacement:

3.1.9

normal operation

operation of the appliance as specified in the following subclauses:

Note 1 to entry: Appliances not mentioned, but which nevertheless perform one of the functions, are operated as specified for this function as far as possible.

3.1.9.101 Barbecues are operated with food supports in the lowest position. Controls are adjusted to the highest setting, any covers or shields being positioned in accordance with the instructions.

Note 1 to entry: **Barbecues** are operated without water even if the use of water is recommended.

3.1.9.102 Breadmakers are operated using the most unfavourable cycle and ingredients specified in the instructions.

Note 1 to entry: The most unfavourable cycle may be for a function such as jam-making that allows the heating element and the kneading motor to operate simultaneously.

3.1.9.103 Candy floss appliances are operated without ingredients.

3.1.9.104 Food dehydrators are operated empty.

3.1.9.105 Hotplates, other than **induction hotplates**, are operated with vessels containing water. The vessels are made of unpolished commercial quality aluminium, have a flat bottom and are covered with a lid. A suitable vessel is specified in Figure 103. Controls are adjusted to their highest setting until the water boils and then adjusted so that the water simmers. Water is added to maintain the level during simmering.

Induction hot plates are operated with vessels as specified in Figure 104, containing cooking oil. Controls are adjusted to their highest setting until the oil temperature reaches $180\text{ °C} \pm 4\text{ °C}$, and are then adjusted so that this temperature is maintained. The oil temperature is measured 1 cm above the centre of the bottom of the vessel. For appliances which cannot heat the oil to $180\text{ °C} \pm 4\text{ °C}$, the control is maintained at its highest setting.

Induction wok hotplates are operated with a wok pan supplied by the manufacturer with the **induction wok hotplate** at the point of sale.

For all **hotplates**, the diameter of the bottom of the vessel is approximately equal to the diameter of the **cooking zone** and the quantity of liquid is specified in Table 101. The vessel is positioned centrally on the **cooking zone**.

Table 101 – Quantity of liquid in the vessel

Diameter of cooking zone mm	Quantity of water or oil l
≤ 110	0,6
> 110 and ≤ 145	1,0
> 145 and ≤ 180	1,5
> 180 and ≤ 220	2,0
> 220 and ≤ 300	3,0

Note 1 to entry: If several **cooking zones** are marked for one **hotplate**, the most unfavourable zone is used for the test.

Note 2 to entry: For non-circular **cooking zones**, the smallest non-circular vessel is used that will cover the **cooking zone** as far as possible, taking into account the **hob rim** and other vessels. The quantity of liquid is determined on the basis of the minor diameter of the **cooking zone**.

3.1.9.106 Ovens are operated with the door or drawer closed. **Ovens** having a **thermostat** are operated so that the mean temperature in the centre of the cavity is maintained at $240\text{ °C} \pm 4\text{ °C}$ or at the value obtained with the **thermostat** adjusted to its highest setting, if this results in a lower temperature. Other **ovens** are operated so that the temperature in the centre of the cavity is maintained at $240\text{ °C} \pm 15\text{ °C}$ by switching the supply on and off.

3.1.9.107 Pop-corn makers are operated with the container filled with the maximum quantity of corn seeds specified in the instructions and, where relevant, with the maximum quantity of oil specified in the instructions.

3.1.9.108 Roasters are operated with the lid closed. The mean temperature in the centre of the container is maintained at $240\text{ °C} \pm 4\text{ °C}$, if necessary by switching the supply on and off.

3.1.9.109 Radiant grills and rotary grills are operated with the controls adjusted in accordance with the instructions or, if instructions are not provided, with the controls adjusted to the highest setting. Doors or lids are open unless otherwise specified in the instructions.

Contact grills having a **thermostat** are operated with the **thermostat** adjusted to the highest setting. Other **contact grills** are operated so that the temperature at the centre of the heated surface is maintained at $275\text{ °C} \pm 15\text{ °C}$ by switching the supply on and off.

Raclette grills are operated with doors or lids open, unless otherwise specified in the instructions. Controls are adjusted in accordance with the instructions, pans being in position or removed, whichever is more unfavourable.

3.1.9.110 Raclette appliances are operated with the controls adjusted in accordance with the instructions or, if instructions are not provided, with the controls adjusted to the highest setting.

3.1.9.111 Rotary grills are operated with the load on the rotating spit shown in Figure 102.

3.1.9.112 Toasters are loaded with the maximum number of slices of white bread specified in the instructions and operated in cycles, each cycle consisting of an operating period and a rest period. The bread is approximately 24 h old and the dimensions of the slices are approximately $100\text{ mm} \times 100\text{ mm} \times 10\text{ mm}$. The rest periods have a duration of 30 s or the minimum period needed for the resetting of a control, whichever is longer. The slices of bread are replaced during each rest period. The operating period is established by adjusting controls to give the bread a golden-brown colour. For **toasters** without a control, each operating period is terminated as soon as the colour of the bread turns golden-brown.

Toasters incorporating a device for heating rolls are loaded with the maximum number of rolls specified in the instructions. The **toaster** is operated in cycles, each cycle consisting of an operating period followed by a rest period of 30 s when the rolls are turned or replaced. The control is adjusted in accordance with the instructions. If instructions are not given, the control is adjusted for the toasting operation.

Sandwich-toasting attachments are loaded with one or more sandwiches that are positioned in accordance with the instructions to produce the most unfavourable result. Each sandwich comprises two slices of white bread filled with a single slice of suitable cheese having an area equal to a slice of bread and a thickness of approximately 5 mm. The toaster is then operated in accordance with the instructions in cycles, each cycle consisting of a toasting operation followed by a rest period of 30 s, or the minimum period needed for the resetting of a control, whichever is longer.

Note 1 to entry: Processed cheese and other cheeses that readily melt when heated are suitable.

3.1.9.113 Waffle irons having a **thermostat** are operated with the **thermostat** adjusted to the highest setting. Other **waffle irons** are operated so that the temperature at the centre of the heated surface is maintained at $210\text{ °C} \pm 15\text{ °C}$ by switching the supply on and off.

3.5 Definitions relating to types of appliances

3.5.101

barbecue

radiant grill having a heating element located under the food support

3.5.102

breadmaker

appliance intended for making bread comprising a heated compartment incorporating dough kneading facilities

3.5.103

candy floss appliance

appliance comprised of a heater and a spinning head intended for preparing candy floss

3.5.104

contact grill

appliance having a heated surface on which food is placed, which can have a second heated surface to cover the food

Note 1 to entry: A **contact grill** with only one heated surface is known as a "griddle".

Note 2 to entry: A sandwich maker is considered as a **contact grill** with two heated surfaces.

3.5.105

cooker

appliance incorporating a **hotplate** and an **oven**

Note 1 to entry: **Cookers** may incorporate a grill.

3.5.106

food dehydrator

appliance for dehydrating food by means of heated air

Note 1 to entry: The appliance may incorporate a fan.

3.5.107

hotplate

appliance having one or more **heating units** on which vessels can be placed for cooking purposes

Note 1 to entry: **Hotplates** do not incorporate an **oven** or grill.

3.5.108

induction hotplate

hotplate that can heat at least one metallic vessel by means of eddy currents

Note 1 to entry: The eddy currents are induced in the bottom of the vessel by the electromagnetic field of a coil.

3.5.109

induction wok hotplate

induction hotplate with a surface of an approximate spherical shape to accept a wok that is supplied with the appliance at the point of sale

3.5.110

oven

appliance having a heated cavity with a door or drawer and constructed so that food that may be in a container can be placed on a shelf

3.5.111**pop-corn maker**

appliance for heating corn seeds until they pop

3.5.112**raclette appliance**

radiant grill for melting the surface of a large piece of cheese

3.5.113**raclette grill**

appliance for melting slices of cheese placed in small pans positioned under the heating element

Note 1 to entry: **Raclette grills** may have a surface that is used as a griddle.

3.5.114**radiant grill**

appliance having a **visibly glowing heating element** and a support on which food can be placed

3.5.115**roaster**

appliance having a heated container with a lid and constructed so that food can be placed in it

3.5.116**rotary grill**

appliance having a **visibly glowing heating element** and a rotating spit to support the food

Note 1 to entry: A **rotary grill** is also known as a "rotisserie".

3.5.117**toaster**

appliance intended for toasting slices of bread by radiant heat

3.5.118**waffle iron**

appliance having two heated hinged plates that are shaped to contain batter

3.6 Definitions relating to parts of an appliance**3.6.101****cooking zone**

area marked on a **hotplate** where the vessel is placed for heating food

3.6.102**heating unit**

part of the appliance that fulfils an independent cooking or warming function

3.6.103**hot functional surface**

surface that is intentionally heated by an internal heat source and that has to be hot to carry out the intended function of the appliance

3.6.104**sandwich-toasting attachment**

accessory for use with a **toaster** for toasting sandwiches

3.6.105

touch control

control actuated by contact or proximity of a finger, with little or no movement of the contact surface

4 General requirement

This clause of Part 1 is applicable.

5 General conditions for the tests

This clause of Part 1 is applicable except as follows.

5.2 Addition:

NOTE 101 If the test of 15.101 has to be carried out, three additional samples are required.

5.3 Addition:

If it is evident from the construction of the appliance that the test of one function will produce more favourable results than another, this function is not tested.

5.6 Addition:

If two or more cooking functions can be performed simultaneously, they are tested at the same time.

5.101 Induction hotplates are operated as specified for **motor-operated appliances**. Other appliances are tested as specified for **heating appliances**, even if they incorporate motors.

*In appliances that incorporate **induction hotplates** in addition to other **heating units**, the **induction hotplates** are operated simultaneously and supplied separately.*

6 Classification

This clause of Part 1 is applicable except as follows.

6.2 Addition:

Appliances intended for outdoor use shall be at least IPX4.

7 Marking and instructions

This clause of Part 1 is applicable except as follows.

7.1 Addition:

The **rated power input** or **rated current** of **induction hotplates** shall also be marked.

Appliances intended to be partially immersed in water for cleaning shall be marked with the maximum level of immersion and the substance of the following:

Do not immerse beyond this level.

If appliances have **accessible surfaces**, for which temperature rise limits are specified in Table 102 and for which the provisions of footnote b to Table 102 apply, then the appliance shall be marked with symbol IEC 60417-5041(2002-10), the rules of ISO 3864-1 applying except for the specified colours, or marked with the substance of the following:

CAUTION: Hot surfaces.

7.6 Addition:



[symbol IEC 60417-5041 (2002-10)] caution, hot surface

7.12 Addition:

The instructions for appliances incorporating an appliance inlet, and intended to be partially or fully immersed in water for cleaning, shall state that the connector must be removed before the appliance is cleaned and that the appliance inlet must be dried before the appliance is used again.

The instructions for appliances intended to be used with a connector incorporating a **thermostat** shall state that only the appropriate connector must be used.

The instructions for appliances intended for outdoor use shall include the substance of the following:

- the appliance is suitable for outdoor use;
- the supply cord should be regularly examined for signs of damage, and if the cord is damaged, the appliance must not be used;
- the appliance must be supplied through a residual current device (RCD) having a rated residual operating current not exceeding 30 mA;
- the appliance is to be connected to a socket-outlet having an earthing contact (for **class I appliances**).

If symbol IEC 60417-5041(2002-10) is marked on appliances, its meaning shall be explained.

The instructions shall state that appliances are not intended to be operated by means of an external timer or separate remote-control system.

The instructions shall include details on how to clean surfaces in contact with food. For **toasters**, they shall include details on how to remove breadcrumbs, when applicable.

The instructions for **toasters** shall include the substance of the following:

The bread may burn, therefore do not use the toaster near or below combustible material, such as curtains.

The instructions for **barbecues** shall include the substance of the following:

WARNING: Charcoal or similar combustible fuels must not be used with this appliance.

The instructions for **barbecues** intended to be used with water shall state the maximum quantity of water to be poured into the appliance.

The instructions for **hotplates** having surfaces of glass-ceramic or similar material protecting **live parts** shall include the substance of the following:

WARNING: If the surface is cracked, switch off the appliance to avoid the possibility of electric shock.

The instructions for **induction hotplates** shall include the substance of the following:

Metallic objects such as knives, forks, spoons and lids should not be placed on the hotplate since they can get hot.

The instructions for **breadmakers** shall state the maximum quantities of flour and raising agent that may be used.

The instructions for **candy floss appliances** shall state the maximum quantities of sugar and other ingredients that may be used.

The instructions shall include the substance of the following:

This appliance is intended to be used in household and similar applications such as:

- staff kitchen areas in shops, offices and other working environments;
- farm houses;
- by clients in hotels, motels and other residential type environments;
- bed and breakfast type environments.

If the use of the appliance is limited to less than the above, this shall be clearly stated in the instructions.

7.14 Addition:

The height of the triangle used with symbol IEC 60417-5041(2002-10) shall be at least 20 mm.

7.15 Addition:

The marking specified for hot surfaces shall be visible when the appliance is operated as in normal use, including when actuating any switch, adjusting any control or opening a lid, door or drawer. It shall not be placed on a **hot functional surface**.

7.101 The **cooking zone** of **hot plates** shall be identified by appropriate marking unless it is obvious.

Compliance is checked by inspection.

8 Protection against access to live parts

This clause of Part 1 is applicable except as follows.

8.1.1 Addition:

*For toasters having a crumb tray, the test finger is not applied through the crumb-tray opening to **live parts** that are disconnected by the operation of a double pole switch. However, it shall not be possible to touch these parts with test probe 41 of IEC 61032.*

8.1.3 Addition:

For **toasters**, it is not necessary for the heating element switching device to provide full disconnection or meet the **clearances** for full disconnection specified in 20.1.5.3 of IEC 61058-1:2000 obtained from Table 22 of IEC 61058-1:2000.

9 Starting of motor-operated appliances

This clause of Part 1 is not applicable.

10 Power input and current

This clause of Part 1 is applicable except as follows.

10.1 Addition:

The power input of **induction hotplates** is measured separately and the tolerances for **motor-operated** appliances apply.

10.2 Addition:

The current of **induction hotplates** is measured separately and the tolerances for **motor-operated** appliances apply.

11 Heating

This clause of Part 1 is applicable except as follows.

11.1 Addition:

Compliance for **toasters** is also checked by the test of 11.101.

Compliance for **ovens, rotary grills and cookers** is also checked by the test of 11.102.

Compliance for **contact grills, waffle irons, radiant grills, raclette grills, barbecues, candy floss appliances and hot plates**, is also checked by the test of 11.103.

Compliance for **breadmakers, pop-corn makers, and food dehydrators** is also checked by the test of 11.104.

Compliance for **roasters** is also checked by the test of 11.105.

For all other types of appliances, compliance is checked by submitting the appliance to the tests of the nearest mentioned relevant type of appliance.

11.2 Addition:

Radiant grills and raclette grills that are loaded from the front, **rotary grills, ovens, breadmakers, cookers and hotplates** are placed with their backs as near as possible to one of the walls of the test corner and away from the other wall. Other appliances are placed away from the walls.

11.3 Addition:

Where the external **accessible surfaces** are suitably flat and access permits, then the test probe of Figure 105 is used to measure the temperature rises of external **accessible surfaces** specified in Table 102. The probe is applied with a force of $4\text{ N} \pm 1\text{ N}$ to the surface in such a way that the best possible contact between the probe and the surface is ensured. The measurement is performed after a contact period of 30 s.

The probe may be held in place using a laboratory stand clamp or similar device. Any measuring instrument giving the same results as the probe may be used.

11.4 Addition:

Breadmakers are operated as specified for **combined appliances**.

If the temperature rise limits are exceeded in appliances incorporating motors, transformers or **electronic circuits**, and the power input is lower than the **rated power input**, the test is repeated with the appliance supplied at 1,06 times **rated voltage**.

11.6 Addition:

Induction hot plates are also operated with vessels, as specified in Figure 104, containing water and covered with a lid. Controls are adjusted to their highest setting until the water boils and then adjusted so that the water simmers. Water is added to maintain the level during simmering.

11.7 Replacement:

Breadmakers are operated for one cycle.

Pop-corn makers are operated until steady conditions are established. If popping of more than one container load of corn seed is required to reach steady conditions, the container is refilled as quickly as possible and the test is then continued without a rest period.

Toasters are operated for 15 min. Unless they are constructed to toast only one slice of bread, they are tested for a further 5 min with one slice of bread inserted in the most unfavourable position.

Toasters incorporating a device for heating rolls are operated for five cycles.

Toasters having **sandwich-toasting attachments** are also tested for five cycles of operation. They are also tested for one cycle of operation with the sandwich in the most unfavourable position.

Radiant grills are operated for a period of 30 min, for the maximum period indicated in the instructions or for the maximum period allowed by a timer, whichever is the longer.

Ovens, roasters and rotary grills are operated until steady conditions are established but for not longer than 60 min. However, if a **rotary grill** has a timer, the timer is reset as many times as necessary to establish steady conditions.

Contact grills having **thermostats** are operated until steady conditions are established. Other **contact grills** are operated for 30 min after the centre of the heating surface attains a temperature of 275 °C.

Waffle irons are operated until steady conditions are established but for not longer than 30 min after the centre of the heating surface attains a temperature of 210 °C.

Raclette grills, barbecues and food dehydrators are operated until steady conditions are established.

Induction hotplates are operated for 30 min. Other **hotplates** are operated for 60 min.

For **cookers**, combinations of **heating units** that can be energised simultaneously are tested together, the **heating units** being switched on for the duration specified.

Candy floss appliances are operated until steady conditions are established.

NOTE 101 If the appliance is subjected to more than one test, it is cooled to room temperature before each test.

11.8 Modification:

For **radiant grills, rotary grills, raclette grills, hotplates and cookers**, instead of 65 K, the temperature rise of the wall of the test corner shall not exceed 75 K.

Addition:

When an appliance connector incorporates a **thermostat**, the temperature rise limit for the pins of the appliance inlet does not apply.

The temperature rise limits of motors, transformers and components of **electronic circuits**, including parts directly influenced by them, may be exceeded when the appliance is operated at 1,15 times the **rated power input**.

Cheese used in **sandwich toasting attachments** shall not flow into places where it could give rise to a hazard, such as reducing **clearances or creepage distances** below the values specified in Clause 29.

The temperature rise limits for touch controls also include all surfaces within 5 mm of the touch controls, regardless of their shape.

Table 102 – Temperature rises for external surfaces

Surface ^a	Temperature rise of external surfaces K ^b
Bare metal	45
Coated metal ^e	55
Glass and ceramic	60
Plastic and plastic coating > 0,4 mm ^{c, d}	65

^a The following surfaces or elements shall not be taken into consideration:

- **hot functional surfaces;**
- handles or control knobs including keypads, keyboards and the like: part of the equipment that a user needs to touch to operate or adjust the equipment. The equipment has to be installed according to the manufacturer's instructions;
- surfaces of heated cavities.

^b When the required values are not met, the maximum temperature rise shall not be higher than two times the values indicated.

^c The temperature rise limit of plastic also applies for plastic material having a metal finish of thickness less than 0,1 mm.

^d When the thickness of the plastic coating does not exceed 0,4 mm, the temperature rise limits of the coated metal or of glass and ceramic material apply.

^e Metal is considered coated when a coating having a minimum thickness of 90 µm made by enamel, powder or non-substantially plastic coating is used.

11.101 Toasters are placed as specified in 11.2 and are operated for three cycles at **rated power under normal operation**.

During the test, the temperature rise of surfaces shall not exceed the values specified in Table 102.

Temperature rises are not measured on:

- *the top side of top loaded appliances and surfaces within 25 mm below the top surface;*
- *surfaces within 25 mm around the outline of the **hot functional surface**;*
- *surfaces within 25 mm from the ventilation openings;*
- *underside surfaces that are not accessible with test probe 41 of IEC 61032, the probe being applied with a force not exceeding 1 N.*

11.102 Ovens, rotary grills and cookers are placed as specified in 11.2 and are supplied at **rated power input** and operated under **normal operation**.

All heating units that can be energised simultaneously during normal use are switched on.

Ovens are operated without shelves or other accessories.

Temperature rises are not measured on the following surfaces (see Figure 106):

- *surfaces on the oven door or drawer within 10 mm from the edge of the door or drawer (Zone 1);*
- *surfaces around the oven door or drawer within 10 mm from the left, right or lower edge of the door or drawer, or 25 mm from the upper edge of the door or drawer (Zone 2);*
- *surfaces within 25 mm of ventilation openings (Zone 3);*
- *underside surfaces and rear surfaces that are not accessible with test probe 41 of IEC 61032, the probe being applied with a force not exceeding 1 N;*
- *surfaces within 25 mm from the level of the top surface of **cookers** when the **hotplates** are in operation.*

Appliances are operated until steady conditions are established or for 60 min, whichever is shorter.

During the test, the temperature rise of surfaces shall not exceed the values specified in Table 102.

Ovens having settings higher than 240 °C are also operated at the maximum setting until steady conditions are established or for 60 min, whichever is shorter. The temperature rise limits of Table 102 for top surfaces and door or drawer surfaces are increased by 10 K.

11.103 Contact grills, waffle irons, radiant grills, raclette grills, barbecues, candy floss appliances and hot plates are placed as specified in 11.2 and are supplied at **rated power input** and operated under **normal operation**. **Induction hotplates and induction wok hotplates** are operated at **rated voltage** instead of **rated power input**.

*The test for **barbecues** is repeated with an aluminium plate placed on the food support. The aluminium plate shall be approximately 1,5 mm thick and shall be made of commercially available aluminium. Its dimensions shall be such that there is a 10 mm gap between the edges of the plate and outer edges of the food support.*

During the test, the temperature rise of surfaces shall not exceed the values specified in Table 102.

Temperature rises are not measured on

- *surfaces within 25 mm around the outline of the **hot functional surface**;*
- *surfaces within 25 mm from the ventilation openings;*
- *underside surfaces that are not accessible with test probe 41 of IEC 61032, the probe being applied with a force not exceeding 1 N;*
- *the lid of griddles, if any, used to prevent splashing.*

11.104 Breadmakers, pop-corn makers and food dehydrators are placed as specified in 11.2 and operated under **normal operation**. **Pop-corn makers and food dehydrators** are supplied at **rated power input** and **breadmakers** are supplied at **rated voltage**.

During the test, the temperature rise of surfaces shall not exceed the values specified in Table 102.

Temperature rises are not measured on

- *surfaces within 25 mm from the edge of the lid;*
- *surfaces within 25 mm from the ventilation openings;*
- *windows and surfaces within 25 mm from the edge of the window;*
- *underside surfaces that are not accessible with test probe 41 of IEC 61032, the probe being applied with a force not exceeding 1 N.*

11.105 Roasters are placed as specified in 11.2 and are supplied at **rated power input** and operated under **normal operation**.

During the test, the temperature rise of surfaces shall not exceed the values specified in Table 102.

Temperature rises are not measured on:

- *the lids;*
- *surfaces within 25 mm from the edge of the lid;*
- *surfaces within 25 mm from the ventilation openings;*
- *underside surfaces that are not accessible with probe 41 of IEC 61032, the probe being applied with a force not exceeding 1 N.*

12 Void

13 Leakage current and electric strength at operating temperature

This clause of Part 1 is applicable except as follows.

13.1 Addition:

If a grill is incorporated in an oven, either the oven or the grill is operated, whichever is more unfavourable.

Induction wok hotplates are operated with the wok pan that is supplied by the manufacturer with the induction wok hotplate at the point of sale.

13.2 Addition:

*If there is earthed metal between **live parts** and the surface of glass-ceramic or similar material of **hotplates**, the leakage current is measured between **live parts** and each vessel in turn connected to the earthed metal. It shall not exceed 0,75 mA. If there is no earthed metal, the leakage current, measured between **live parts** and each of the vessels in turn, shall not exceed 0,25 mA.*

13.3 Addition:

*If there is earthed metal between **live parts** and the surface of glass-ceramic or similar material of **hotplates**, a test voltage of 1 000 V is applied between **live parts** and all the vessels connected to the earthed metal. If there is no earthed metal, a test voltage of 3 000 V is applied between **live parts** and the vessels.*

14 Transient overvoltages

This clause of Part 1 is applicable.

15 Moisture resistance

This clause of Part 1 is applicable except as follows.

15.2 Addition:

*For **ovens**, 0,5 l of water containing approximately 1 % NaCl is poured uniformly over the bottom surface of the **oven**.*

***Hotplates** and **cookers** are positioned so that the top surface is horizontal. A vessel having the largest diameter shown in Figure 103, which does not exceed the diameter of the **cooking zone**, is completely filled with water containing approximately 1 % NaCl and positioned centrally over the **cooking zone**. A further quantity of approximately 0,5 l of the solution is poured steadily into the vessel over a period of 15 s. The test is carried out on each **cooking zone** in turn, after removing any residual solution from the appliance. For **induction wok hotplates**, the test is performed using the wok pan that is supplied by the manufacturer with the **induction wok hotplate** at the point of sale.*

*If the heating element of a **hotplate** incorporates a thermal control, 0,02 l of the saline solution is poured over the **cooking zone** so that it flows over the control. A vessel is then placed on the **cooking zone** to depress any movable part.*

*For **hotplates** having ventilation openings in the heated surface, 0,2 l of the saline solution is poured steadily through the funnel onto the ventilation openings. The funnel has an outlet diameter of 8 mm and is positioned vertically with the outlet 200 mm above the heated surface. The funnel is positioned above the ventilation openings so that the solution enters the appliance in the most unfavourable way.*

NOTE 101 If the opening is protected, the funnel is positioned so that the solution falls onto the heated surface as close as possible to the opening.

For other appliances with heating elements that are covered by vessels in normal use, the spillage test is carried out by steadily pouring saline solution onto the heating surface over a period of 1 min, 0,1 l of solution being used for every 100 cm² of the heating surface.

*The spillage test is not carried out on **roasters**.*

15.101 Appliances intended to be partially or completely immersed in water for cleaning shall have adequate protection against the effects of immersion.

Compliance is checked by the following tests, which are carried out on three additional appliances.

*The appliances are operated under **normal operation** at 1,15 times **rated power input**, until the **thermostat** operates for the first time. Appliances without a **thermostat** are operated until steady conditions are established. The appliances are disconnected from the supply, any appliance connector being withdrawn. They are then completely immersed in water containing approximately 1 % NaCl and having a temperature between 10 °C and 25 °C, unless they are marked with the maximum level of immersion, in which case they are immersed 5 cm deeper than this level.*

After 1 h, the appliances are removed from the saline solution, dried and subjected to the leakage current test of 16.2. Care shall be taken to ensure that all moisture is removed from the insulation around the pins of appliance inlets.

This test is carried out four more times, after which the appliances shall withstand the electric strength test of 16.3, the voltage being as specified in Table 4.

*The appliance having the highest leakage current after the fifth immersion is dismantled and inspection shall show that there is no trace of liquid on insulation that could result in a reduction of **clearances** and **creepage distances** below the values specified in Clause 29.*

*The remaining two appliances are operated under **normal operation** for 240 h at 1,15 times **rated power input**. After this period, the appliances are disconnected from the supply and immersed again for 1 h. They are then dried and subjected to the electric strength test of 16.3, the voltage being as specified in Table 4.*

*Inspection shall show that there is no trace of liquid on insulation that could result in a reduction of **clearances** and **creepage distances** below the values specified in Clause 29.*

16 Leakage current and electric strength

This clause of Part 1 is applicable except as follows.

16.1 Addition:

*For **hotplates**, the tests are carried out with a vessel as specified for **normal operation** placed on each **cooking zone**.*

***Induction wok hotplates** are operated with the wok pan that is supplied by the manufacturer with the **induction wok hotplate** at the point of sale.*

16.2 Addition:

*If there is earthed metal between **live parts** and the surface of glass-ceramic or similar material of **hotplates**, the leakage current is measured between **live parts** and each vessel in turn connected to the earthed metal. It shall not exceed 0,75 mA. If there is no earthed metal, the leakage current, measured between **live parts** and each of the vessels in turn, shall not exceed 0,25 mA.*

16.3 Addition:

*If there is earthed metal between **live parts** and the surface of glass-ceramic or similar material of **hotplates**, a test voltage of 1 250 V is applied between **live parts** and all the vessels connected to the earthed metal. If there is no earthed metal, a test voltage of 3 000 V is applied between **live parts** and the vessels.*

17 Overload protection of transformers and associated circuits

This clause of Part 1 is applicable.

18 Endurance

This clause of Part 1 is not applicable.

19 Abnormal operation

This clause of Part 1 is applicable except as follows.

19.1 Addition:

The tests of 19.4 and 19.5 are only applicable to

- **breadmakers**;
- **food dehydrators**;
- *the following appliances, if they incorporate a timer or if their instructions indicate a cooking operation longer than 1 h:*
 - **cookers**;
 - **hotplates other than induction hotplates**;
 - **ovens**;
 - **roasters**;
 - **rotary grills**.

Toasters are also subjected to the tests of 19.101, 19.102 and 19.103.

*Induction hotplates are also subjected to the tests of 19.104, 19.105 and 19.107, but 19.2, 19.3 and 19.4 are not applicable. However, **induction wok hotplates** are not subjected to the test of 19.104.*

Pop-corn makers are also subjected to the test of 19.106.

19.2 Addition:

***Radiant grills** and **raclette grills** that are loaded from the front, **rotary grills**, **ovens**, **hotplates** and **cookers** are placed as near to the walls of the test corner as possible.*

*Appliances are tested empty. Lids, drawers and doors are open or closed, whichever is more unfavourable. **Detachable parts** are in position or removed, whichever is more unfavourable.*

***Hotplates** are operated without a vessel and with the controls adjusted to the highest setting.*

***Cookers** are only tested with the **heating unit** that results in the most unfavourable conditions, their controls being adjusted to the highest setting. However, **ovens** are operated*

if they do not have an indicating lamp to show when they are switched on, controls being adjusted to the highest setting.

NOTE 101 A lamp used for illuminating the **oven**, that is visible through the door or drawer and is automatically switched on and off with the **oven**, is considered to be an indicating lamp.

19.4 Addition:

*Air-circulating fans of **food dehydrators** are disconnected.*

19.8 Not applicable.

19.10 Not applicable.

19.11.2 Addition:

*For **toasters** having devices with an off position obtained by electronic disconnection, the fault conditions a) to g) are also simulated with the appliance supplied at **rated voltage** but with the controls switched off.*

Heating elements shall not become energized.

19.13 Addition:

*During the test of 19.102 and 19.103, flames from the bread inside the **toaster** and any smoke from the bread shall be ignored.*

*The temperature rise of the windings of **induction hotplates** shall not exceed the values specified in 19.7.*

*The electric strength test of **induction hotplates** is carried out immediately after switching off the appliance.*

19.101 Toasters are operated at **rated power input** and under **normal operation**, but without bread, for six cycles of operation. The appliance is then allowed to cool to approximately room temperature.

This test is carried out 500 times.

The ejector mechanism shall operate satisfactorily and no sustained arcing shall occur. Electrical connections shall not work loose and the appliance shall withstand the electric strength test of 16.3. 19.13 is not applicable.

NOTE 1 Forced cooling can be used.

NOTE 2 A simulated load could be necessary to operate the ejector mechanism.

19.102 Toasters, loaded with the bread specified for **normal operation**, are operated at **rated power input**. The ejector mechanism is prevented from releasing and the supply is maintained to the heating elements after the timer has completed its cycle.

*The test is terminated after any fire has extinguished, after which any residual bread is removed from the **toaster**.*

19.103 Toasters, loaded with the bread specified for **normal operation**, are operated at **rated power input** for 2 cycles with the control at maximum setting. The bread is not replaced.

19.104 Induction hotplates are supplied at **rated voltage** and operated with a steel disk placed on the centre of the **cooking zone**. The disk has a thickness of 6 mm and the smallest diameter, rounded up to the nearest centimetre, which allows the appliance to operate.

19.105 Induction hotplates are supplied at **rated voltage** and operated under **normal operation** but with any control that limits the temperature during the test of Clause 11 short-circuited.

NOTE If the appliance incorporates more than one control, they are short circuited in turn.

The temperature rise of the oil shall not exceed 270 K.

19.106 Pop-corn makers are operated under conditions of Clause 11 for a period of five minutes but with the pop corn outlet blocked by means of a grid with a mesh size small enough to keep the pop corn from being ejected from the appliance.

19.107 Induction hotplates are operated under the conditions of Clause 11 but with empty vessels, controls being adjusted to the highest setting.

Induction wok hotplates are operated under the conditions of Clause 11 with an empty wok pan that is supplied by the manufacturer with the **induction wok hotplate** at the point of sale, controls being adjusted to the highest setting.

20 Stability and mechanical hazards

This clause of Part 1 is applicable except as follows.

20.101 Ovens having doors with a horizontal hinge at their lower edge or drawers and on which a load is likely to be placed shall have adequate stability.

Compliance is checked by the following test.

The oven is placed on a horizontal surface with the door or drawer open and a mass of 3,5 kg is gently placed on the geometric centre of the door or drawer.

NOTE A sandbag can be used for the load.

The oven shall not tilt.

This test is not carried out on ovens with doors having a dimension less than 225 mm from the hinge to the opposite edge or on ovens with doors which cannot support dishes in the fully open position.

21 Mechanical strength

This clause of Part 1 is applicable except as follows.

21.1 Addition:

For appliances intended for outdoor use, the impact energy is increased to 0,7 J.

If the appliance incorporates visibly glowing heating elements enclosed in glass tubes, the blows are applied to the tubes without removing any heater guards as mounted in the appliance if they are

– located at the top of the oven and accessible to test probe 41 of IEC 61032;

– located elsewhere in the oven and accessible to test probe B of IEC 61032.

For **hotplates** having surfaces of glass-ceramic or similar material, three blows are applied to parts of the surface that are not exposed to impacts during the test of 21.101, the impact energy being 0,7 J. The blows are not applied to surfaces within 20 mm of knobs.

NOTE 101 If the surface comprises a single piece of material, except for the outer frame, this test is not carried out.

21.101 Surfaces of **hotplates** of glass-ceramic or similar material shall withstand the stresses liable to occur in normal use.

Compliance is checked by the following test.

Induction wok hotplates are tested with a wok pan that is supplied by the manufacturer with the **induction wok hotplate** at the point of sale. The wok pan is filled with sand or shot so that the total mass, including the mass of the wok pan, is equal to $1,8 \text{ kg} \pm 0,01 \text{ kg}$.

The **hotplate** is operated at **rated power input** with its control adjusted to the highest setting. **Induction hotplates** are operated as specified in Clause 11. When steady conditions are established, the **hotplate** is switched off and a vessel with its base horizontal is dropped from a height of 150 mm onto the **cooking zone**. The vessel has a copper or aluminium base that is flat over a diameter of $120 \text{ mm} \pm 10 \text{ mm}$, its edges being rounded with a radius of at least 10 mm. It is uniformly filled with at least 1,3 kg of sand or shot so that the total mass is $1,80 \text{ kg} \pm 0,01 \text{ kg}$.

The vessel is dropped 10 times onto each **cooking zone**. It is removed and the appliance is operated at **rated power input** until steady conditions are established.

A quantity of $1^{+0,1}_0$ l of water containing approximately 1 % NaCl is poured steadily over the **hotplate**.

The appliance is then disconnected from the supply. After 15 min, all excess liquid is removed and the appliance is allowed to cool to approximately room temperature. The same quantity of the saline solution is poured over the **hotplate** after which excess liquid is removed again.

The surface of the **hotplate** shall not be broken and the appliance shall withstand the electric strength test of 16.3.

22 Construction

This clause of Part 1 is applicable except as follows.

22.24 Addition:

Heating elements shall be constructed or supported so they are unlikely to become displaced in normal use.

Compliance is checked by inspection.

22.101 **Radiant grills** shall not incorporate a timer that is intended to delay the operation of a heating element, unless they have a **thermostat** and are incorporated in an **oven** or other compartment. **Hotplates** shall not incorporate a timer that is intended to delay the operation of a heating element.

Compliance is checked by inspection.

22.102 Barbecues shall not have bare heating elements.

Bare heating elements for **ovens** shall only be located at the top of the heated compartment.

Compliance is checked by inspection.

22.103 Oven ventilation openings shall be constructed so that they do not discharge moisture or grease in such a way that **clearances** and **creepage distances** are affected.

Compliance is checked by inspection.

22.104 Ovens shall be constructed so that shelves can easily slide in the supports and do not fall out of position when the sides are displaced as much as possible.

Compliance is checked by inspection and by manual test.

22.105 Appliances shall not have openings on the underside that would allow small items to penetrate and touch **live parts**.

*Compliance is checked by inspection and by measuring the distance between the supporting surface and **live parts** through openings. This distance shall be at least 6 mm. However, if the appliance is fitted with legs, this distance is increased to 10 mm if the appliance is intended to stand on a table and to 20 mm if it is intended to stand on the floor.*

22.106 Grills and **barbecues** shall be constructed so that their heating elements are fixed in position or prevented from operating when they are not in their normal position of use.

The requirement is not applicable if the appliance complies with the standard with the element placed in any position.

Compliance is checked by inspection.

22.107 Hotplates shall be constructed so that heating elements are prevented from rotating about a vertical axis and are adequately supported in all positions of adjustment of their supports.

If a heating element is clamped by a nut on a central stud, an additional means is required to prevent its rotation.

Compliance is checked by inspection.

22.108 Hotplates shall be constructed so that inadvertent operation of **touch controls** is unlikely if this could give rise to a hazardous situation due to

- spillage of liquids, including that caused by a vessel boiling over;
- a damp cloth placed on the control panel.

*Compliance is checked by the following test, the appliance being supplied at **rated voltage**.*

Sufficient water to completely cover the control panel to a depth not exceeding 2 mm, with a minimum of 140 ml, is poured steadily over the control panel so that bridging occurs between combinations of touch pads.

The test is carried out with each heating element energised in turn and then without energising any heating element.

A cloth having a mass between 140 g/m² and 170 g/m² and dimensions of 400 mm × 400 mm is folded four times into a square pad and saturated with water. It is placed over the control panel in any position.

There shall be no inadvertent operation of any heating element for longer than 10 s.

22.109 Hotplates incorporating touch controls shall require at least two manual operations to switch on a heating element but only one to switch it off.

NOTE Touching the contact surface at the same point twice is not considered to be two operations.

Compliance is checked by manual test.

22.110 Induction hotplates shall be constructed so that they can only be operated with a suitable vessel placed on the **cooking zone**.

*Compliance is checked by the following test, the appliance being supplied at **rated voltage**.*

*An iron bar 2 mm thick having dimensions 100 mm × 20 mm is placed in the most unfavourable position on the **cooking zone**. The controls are adjusted to their maximum setting.*

The temperature rise of the bar shall not exceed 35 K.

22.111 Heating elements in breadmakers shall be located so that they are not exposed to dough that may rise over the edge of the dough container during normal use of the appliance.

Compliance is checked by inspection and in case of doubt by the following test.

A dough mixture as specified in the instructions has added ingredients to cause the dough to overflow the pan. The overflowing dough mixture shall not come into contact with the heating elements.

NOTE An overflow can be achieved by increasing the ingredients in incremental amounts (for example 10 %) until overflow is achieved.

22.112 Reconnection of the power supply to a breadmaker after an interruption shall not result in a fire due to an extended heating period.

Compliance is checked by the following test.

*All batteries are removed and the **breadmaker** is supplied at **rated voltage** and operated in its heating mode without a load.*

After 1 min, the power supply is interrupted for a period of 5 min and then restored. The appliance shall continue to operate in its heating mode from the same point in the cycle, or a manual operation shall be required to restart it.

If the appliance continues to operate automatically, the test is repeated but with a 5 min longer period of interruption. If the appliance still continues to operate automatically, the test is repeated but with the periods of interruption increased by at least 5 min each time.

The appliance shall eventually require a manual operation to restart it.

22.113 Toasters having an ejector mechanism shall be constructed so that they switch off automatically after the normal toasting time even if the ejector mechanism is blocked by the bread.

Compliance is checked by the following test.

*The toaster is supplied at **rated voltage** and the ejector mechanism is prevented from releasing. On the completion of the normal toasting time, heating elements shall be automatically disconnected from the supply by at least an **all-pole disconnection**, micro-disconnection. However, a single pole, micro-disconnection is allowed, provided heating elements are not accessible to the test probe 12 of IEC 61032.*

22.114 Heating elements in **candy floss appliances** shall be located so that they are not exposed to sugar during normal use of the appliance.

Compliance is checked by the following test.

*The maximum amount of sugar specified in instructions is scattered onto the most unfavourable places of the upper surface of the **candy floss appliance**. The sugar shall not contact the heating elements.*

22.115 For appliances incorporating a **hotplate** with at least one **heating unit** controlled by an **electronic circuit**, safety shall not be impaired in the event of a fault in the **electronic circuit**.

Compliance is checked by the following test:

*The appliance is operated under the conditions specified in Clause 11 but supplied at **rated voltage**.*

*The fault conditions in a) to g) of 19.11.2 are applied one at a time to the **electronic circuit** controlling the duty cycle of each **hotplate heating unit** in turn. If relays are used to energize the **heating unit**, the relays are rendered inoperative one at a time in addition.*

*The control setting shall not change to a higher setting for longer than 2 min. However, for **induction hotplates**, a change to a higher setting is allowed provided the oil temperature does not exceed 270 K.*

The software used to comply with the requirement shall contain measures to control the fault/error conditions specified in Table R.1 and is evaluated in accordance with the relevant requirements of Annex R.

23 Internal wiring

This clause of Part 1 is applicable except as follows.

23.3 Addition:

For appliances that can be opened to two positions, 1 000 flexings are made with the part moved to the fully open position and the remaining flexings to the other position.

24 Components

This clause of Part 1 is applicable except as follows.

24.1.3 Addition:

*Switches controlling heating elements of **hotplates** are subjected to 30 000 cycles of operation.*

Switches controlling heating elements of **toasters** are subjected to 50 000 cycles of operation.

24.1.4 Modification:

The following numbers of cycles of operation apply:

- **energy regulators**
 - for automatic action 100 000
 - for manual action 10 000
- **self-resetting thermal cut-outs**
 - for heating elements of glass-ceramic **hotplates** 100 000
 - for heating elements of other **hotplates** 10 000

24.1.5 Addition:

For appliance couplers incorporating **thermostats**, **thermal cut-outs** or fuses in the connectors, IEC 60320-1 is applicable except that

- the earthing contact of the connector is allowed to be accessible, provided that this contact is not likely to be gripped during insertion or withdrawal of the connector;
- the temperature required for the test of Clause 18 is that measured on the pins of the appliance inlet during the test of Clause 11 of this standard;
- the breaking-capacity test of Clause 19 is carried out using the inlet of the appliance;
- the temperature rise of current-carrying parts specified in Clause 21 is not determined.

NOTE 101 Thermal controls are not allowed in connectors complying with the standard sheets of IEC 60320-1.

24.101 Thermostats and energy regulators incorporating an **off position** shall not switch on as a result of variations in ambient temperature.

Compliance is checked by the following test that is carried out on three devices.

The device, set at the **off position**, is placed for 2 h in an ambient temperature of -20_{-5}^0 °C and then at

- t °C, where t is the temperature according to the T-marking;
- 55 °C, for devices without a T-marking.

During the test the **off position** shall be maintained.

A test voltage of 500 V is applied across the contacts for 1 min. No breakdown shall occur.

24.102 Thermal cut-outs incorporated in food dehydrators for compliance with 19.4 shall not be **self-resetting thermal cut-outs**.

Compliance is checked by inspection.

25 Supply connection and external flexible cords

This clause of Part 1 is applicable except as follows.

25.1 Addition:

Appliances incorporating an appliance inlet that does not comply with the standard sheets of IEC 60320-3 shall be supplied with a cord set.

25.7 Addition:

The **supply cord** of appliances intended for outdoor use shall be polychloroprene sheathed and shall not be lighter than ordinary polychloroprene sheathed flexible cord (code designation 60245 IEC 57).

26 Terminals for external conductors

This clause of Part 1 is applicable.

27 Provision for earthing

This clause of Part 1 is applicable except as follows.

27.1 Addition:

Earthing continuity shall not depend upon flexible metallic tubes, coiled springs or cord anchorages.

28 Screws and connections

This clause of Part 1 is applicable.

29 Clearances, creepage distances and solid insulation

This clause of Part 1 is applicable except as follows.

29.2 Addition:

The microenvironment is pollution degree 3 unless the insulation is enclosed or located so that it is unlikely to be exposed to pollution during normal use of the appliance.

29.3 Addition:

This requirement does not apply to the sheath of a **visibly glowing heating element** that is inaccessible to test probe 41 of IEC 61032.

30 Resistance to heat and fire

This clause of Part 1 is applicable except as follows.

30.1 Addition:

Temperature rises occurring during the test of 19.102 are not taken into account.

30.2 Addition:

The tests of 30.2.3 are applicable to

- **breadmakers;**
- **food dehydrators;**
- *the following appliances if they incorporate a timer or if their instructions indicate a cooking operation longer than 1 h:*
 - **cookers;**
 - **hotplates;**
 - **ovens;**
 - **roasters;**
 - **rotary grills.**

For other appliances, the tests of 30.2.2 are applicable.

31 Resistance to rusting

This clause of Part 1 is applicable except as follows.

Addition:

For appliances intended for outdoor use, compliance is checked by the salt mist test, Kb, of IEC 60068-2-52, severity 2 being applicable.

Before the test, enclosures having a coating are scratched by means of a hardened steel pin, the end of which has the form of a cone with a top angle of 40°. Its tip is rounded with a radius of 0,25 mm ± 0,02 mm. The pin is loaded so that the force exerted along its axis is 10 N ± 0,5 N. The pin is held at an angle of 80° to 85° to the horizontal and scratches are made by drawing the pin along the surface of the coating at a speed of approximately 20 mm/s. Five scratches are made at least 5 mm apart and at least 5 mm from the edges.

After the test, the appliance shall not have deteriorated to such an extent that compliance with this standard, in particular with Clauses 8 and 27, is impaired. The coating shall not be broken and shall not have loosened from the surface.

32 Radiation, toxicity and similar hazards

This clause of Part 1 is applicable.

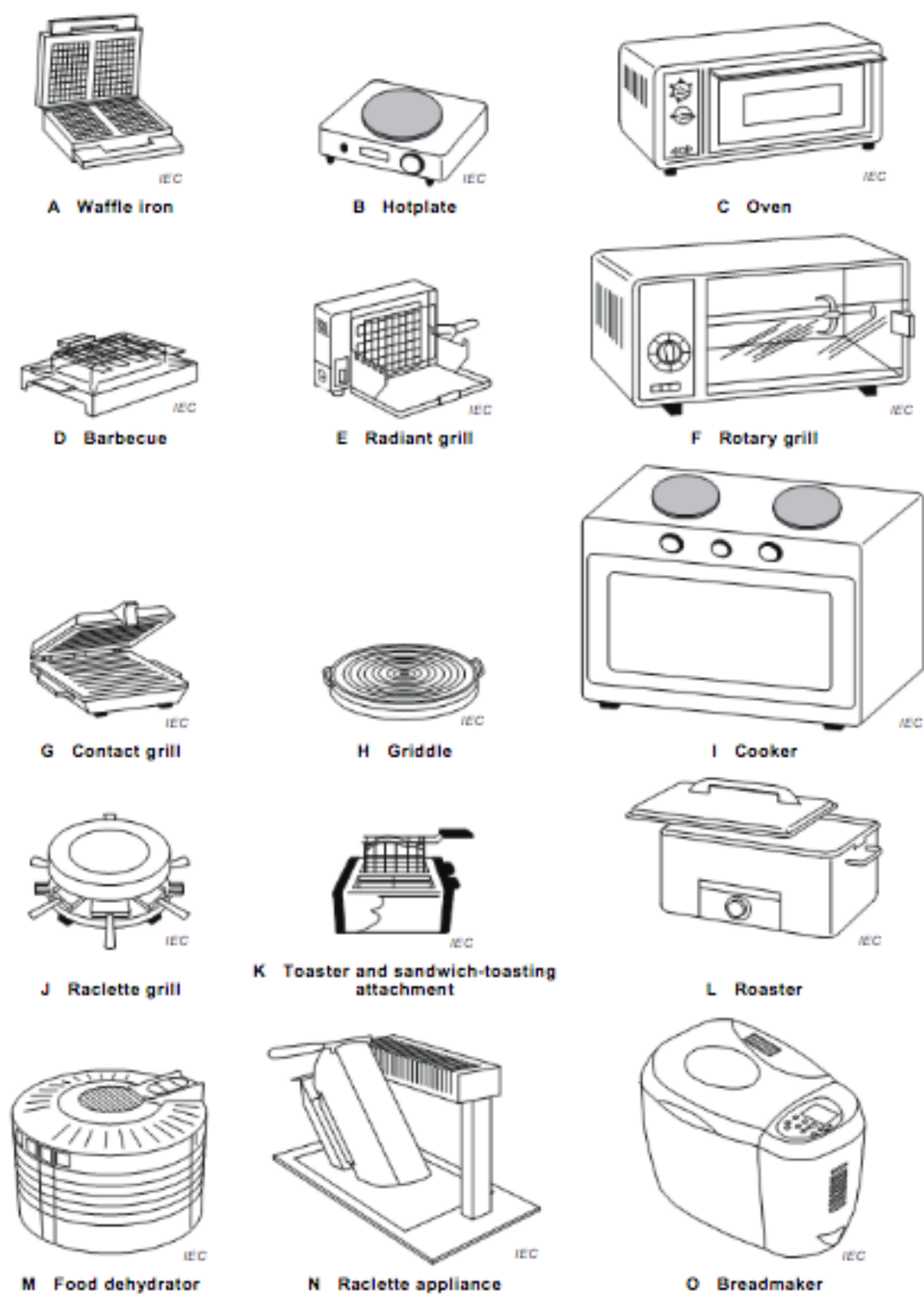

Figure 101 – Examples of appliances

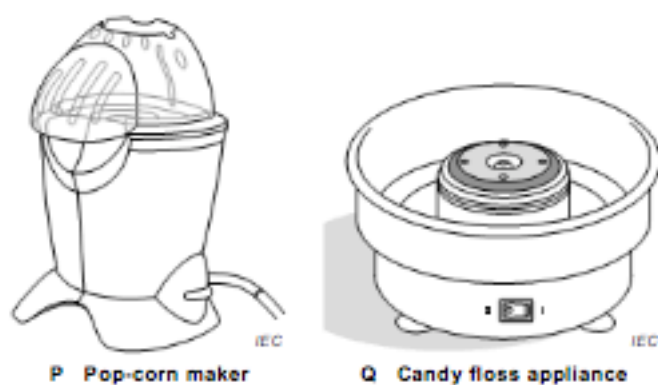
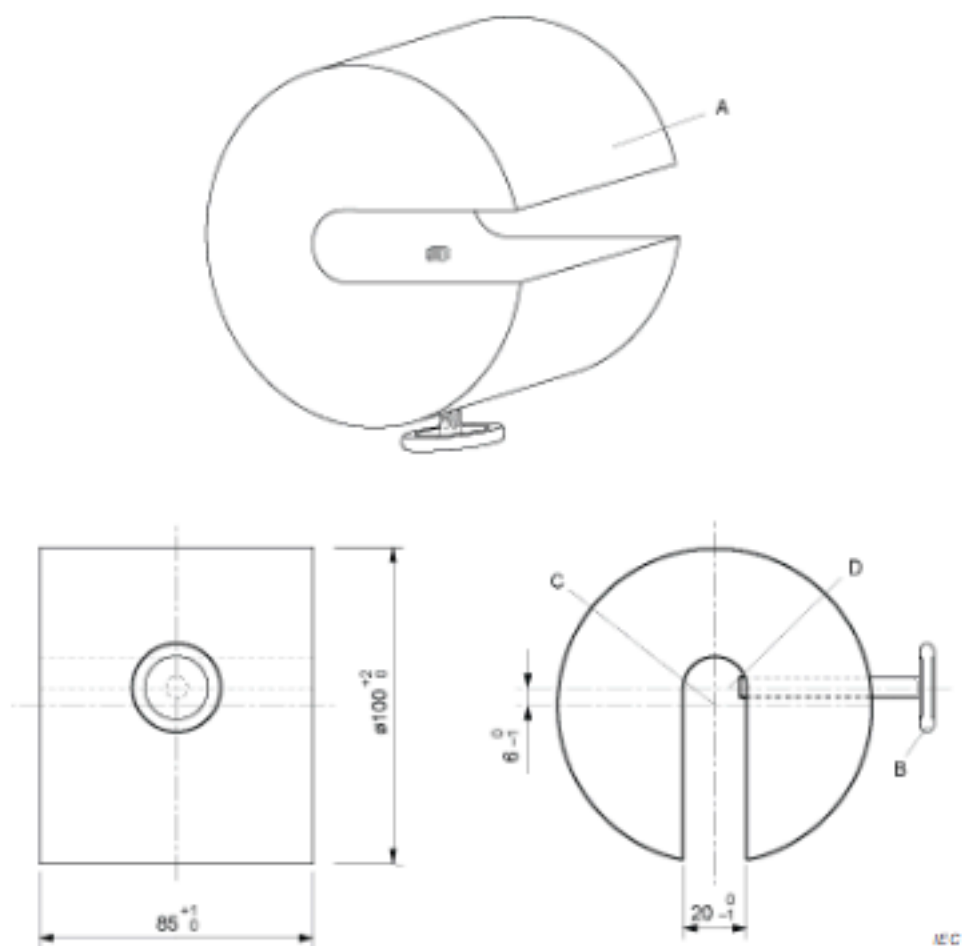

Figure 101 – Examples of appliances (*concluded*)

Dimensions in millimetres

**Key**

- A load, mass approximately 4,5 kg
- B fixing screw
- C axis of load
- D axis of fixing screw

The load is positioned on the rotary spit so that the fixing screw contacts the diameter of the spit.

Figure 102 – Load for testing rotating spits

Dimensions in millimetres

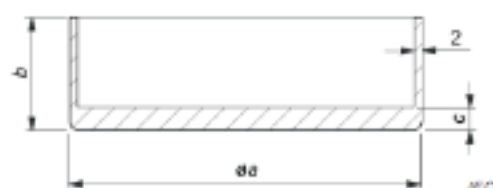

Diameter of cooking zone mm	Approximate dimension		
	a mm	b mm	c mm
≤ 110	110	140	8
> 110 ≤ 145	145	140	8
> 145 ≤ 180	180	140	9
> 180 ≤ 220	220	120	10
> 220 ≤ 300	300	100	10

The base of the vessel shall not be convex. The concavity of the base of the vessel shall not exceed 0,05 mm.

Figure 103 – Vessel for testing hotplates

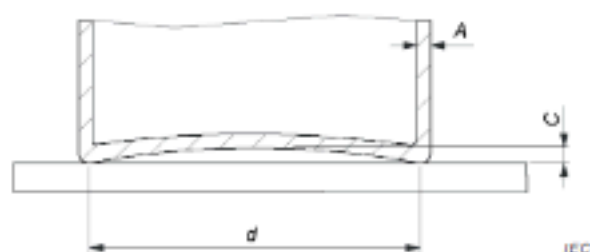

Key

A base and wall thickness, 2 mm ± 0,5 mm

C maximum concavity

d diameter of the flat area of the base

The vessel is made of low carbon steel having a maximum carbon content of 0,08 %. It is cylindrical without metallic handles or protrusions. The diameter of the flat area of the base of the vessel shall be at least the diameter of the **cooking zone**. The base of the vessel shall not be convex. The concavity of the base of the vessel shall not exceed 0,006 d.

Figure 104 – Vessel for testing induction hotplates

Dimensions in millimetres

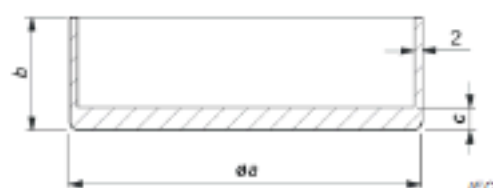

Diameter of cooking zone mm	Approximate dimension		
	a mm	b mm	c mm
≤ 110	110	140	8
> 110 ≤ 145	145	140	8
> 145 ≤ 180	180	140	9
> 180 ≤ 220	220	120	10
> 220 ≤ 300	300	100	10

The base of the vessel shall not be convex. The concavity of the base of the vessel shall not exceed 0,05 mm.

Figure 103 – Vessel for testing hotplates

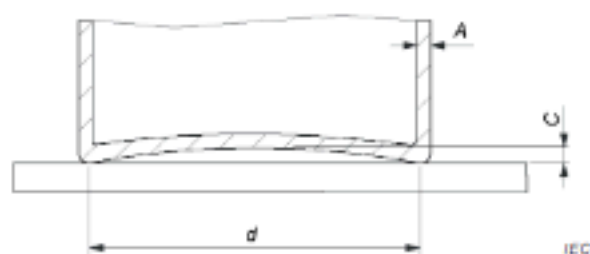

Key

A base and wall thickness, 2 mm ± 0,5 mm

C maximum concavity

d diameter of the flat area of the base

The vessel is made of low carbon steel having a maximum carbon content of 0,08 %. It is cylindrical without metallic handles or protrusions. The diameter of the flat area of the base of the vessel shall be at least the diameter of the **cooking zone**. The base of the vessel shall not be convex. The concavity of the base of the vessel shall not exceed 0,006 d.

Figure 104 – Vessel for testing induction hotplates

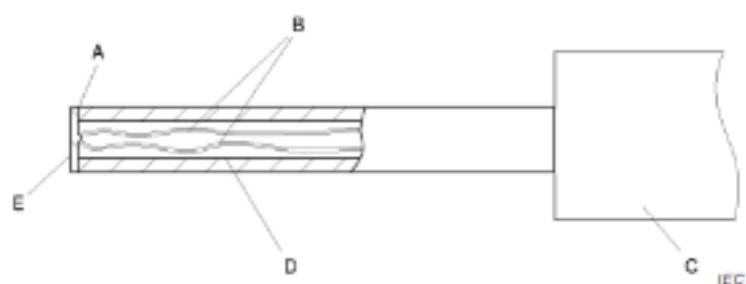

Key

- A adhesive
- B thermocouple wires 0,3 mm diameter to IEC 60584-1 Type K (chrome alumel)
- C handle arrangement permitting a contact force of $4\text{ N} \pm 1\text{ N}$
- D polycarbonate tube: inside diameter 3 mm, outside diameter 5 mm
- E tinned copper disc: 5 mm diameter, 0,5 mm thick

Figure 105 – Probe for measuring surface temperatures

Dimensions in millimetres

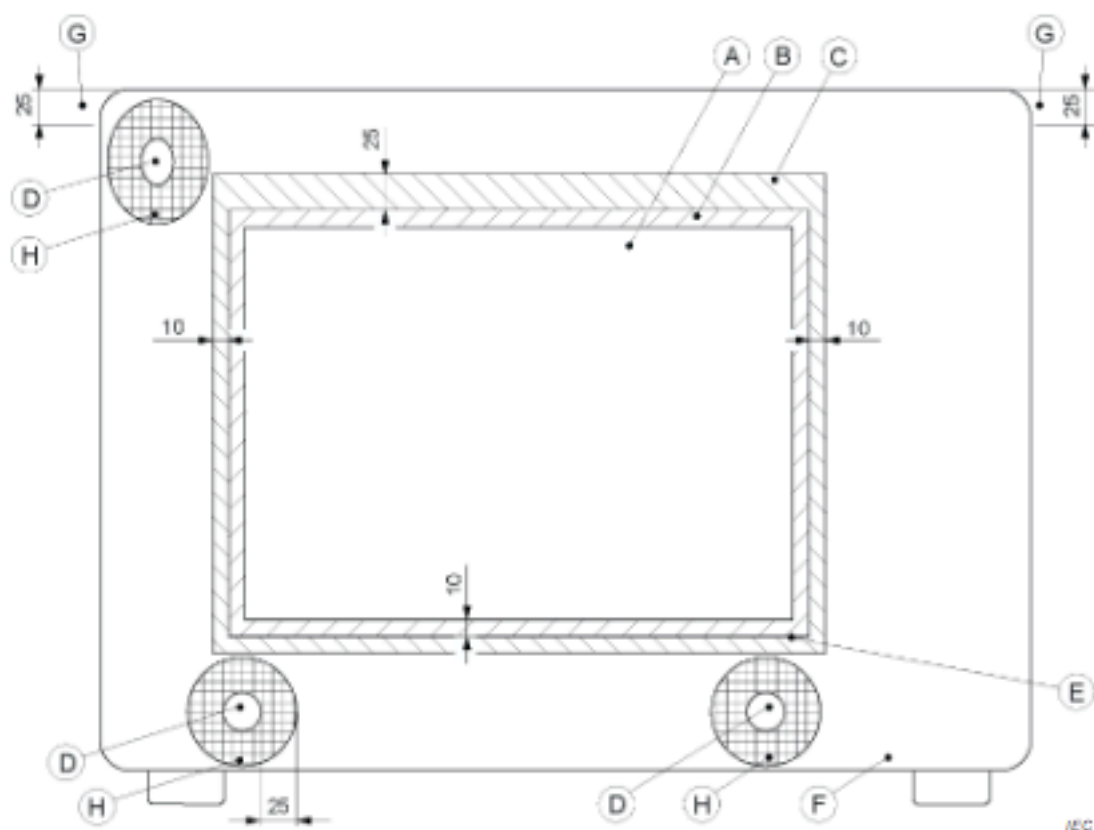
**Key**

- A door or drawer
- B excluded area on the door or drawer (Zone 1)
- C excluded area around the door or drawer (Zone 2)
- D ventilation opening
- E door gap
- F oven front surface
- G excluded area on sidewall
- H excluded area around ventilation opening (Zone 3)

Figure 106 – Front view of appliance with identification of excluded areas

Annexes

The annexes of Part 1 are applicable except as follows.

Annex C
(normative)

Ageing test on motors

Modification:

The value of p in Table C.1 is 2 000.

Annex R **(normative)**

Software evaluation

R.2.2.5 *Modification:*

For **programmable electronic circuits** with functions requiring software incorporating measures to control the fault/error conditions specified in Table R.1, detection of a fault/error shall occur before compliance with Clause 19 and 22.115 is impaired.

R.2.2.9 *Modification:*

The software and safety-related hardware under its control shall be initialized and shall terminate before compliance with Clause 19 and 22.115 is impaired.

Bibliography

The bibliography of Part 1 is applicable except as follows.

Addition:

IEC 60335-2-6, *Household and similar electrical appliances – Safety – Part 2-6: Particular requirements for stationary cooking ranges, hobs, ovens and similar appliances*

IEC 60335-2-12, *Household and similar electrical appliances – Safety – Part 2-12: Particular requirements for warming plates and similar appliances*

IEC 60335-2-13, *Household and similar electrical appliances – Safety – Part 2-13: Particular requirements for deep fat fryers, frying pans and similar appliances*

IEC 60335-2-25, *Household and similar electrical appliances – Safety – Part 2-25: Particular requirements for microwave ovens, including combination microwave ovens*

IEC 60335-2-78, *Household and similar electrical appliances – Safety – Part 2-78: Particular requirements for outdoor barbecues*
