

INTERNATIONAL STANDARD

NORME INTERNATIONALE

**Household and similar electrical appliances – Safety –
Part 2-15: Particular requirements for appliances for heating liquids**

**Appareils électrodomestiques et analogues – Sécurité –
Partie 2-15: Exigences particulières pour les appareils de chauffage des liquides**





THIS PUBLICATION IS COPYRIGHT PROTECTED
Copyright © 2012 IEC, Geneva, Switzerland

All rights reserved. Unless otherwise specified, no part of this publication may be reproduced or utilized in any form or by any means, electronic or mechanical, including photocopying and microfilm, without permission in writing from either IEC or IEC's member National Committee in the country of the requester.

If you have any questions about IEC copyright or have an enquiry about obtaining additional rights to this publication, please contact the address below or your local IEC member National Committee for further information.

Droits de reproduction réservés. Sauf indication contraire, aucune partie de cette publication ne peut être reproduite ni utilisée sous quelque forme que ce soit et par aucun procédé, électronique ou mécanique, y compris la photocopie et les microfilms, sans l'accord écrit de la CEI ou du Comité national de la CEI du pays du demandeur.

Si vous avez des questions sur le copyright de la CEI ou si vous désirez obtenir des droits supplémentaires sur cette publication, utilisez les coordonnées ci-après ou contactez le Comité national de la CEI de votre pays de résidence.

IEC Central Office
3, rue de Varembe
CH-1211 Geneva 20
Switzerland

Tel.: +41 22 919 02 11
Fax: +41 22 919 03 00
info@iec.ch
www.iec.ch

About the IEC

The International Electrotechnical Commission (IEC) is the leading global organization that prepares and publishes International Standards for all electrical, electronic and related technologies.

About IEC publications

The technical content of IEC publications is kept under constant review by the IEC. Please make sure that you have the latest edition, a corrigenda or an amendment might have been published.

Useful links:

IEC publications search - www.iec.ch/searchpub

The advanced search enables you to find IEC publications by a variety of criteria (reference number, text, technical committee,...).

It also gives information on projects, replaced and withdrawn publications.

IEC Just Published - webstore.iec.ch/justpublished

Stay up to date on all new IEC publications. Just Published details all new publications released. Available on-line and also once a month by email.

Electropedia - www.electropedia.org

The world's leading online dictionary of electronic and electrical terms containing more than 30 000 terms and definitions in English and French, with equivalent terms in additional languages. Also known as the International Electrotechnical Vocabulary (IEV) on-line.

Customer Service Centre - webstore.iec.ch/csc

If you wish to give us your feedback on this publication or need further assistance, please contact the Customer Service Centre: csc@iec.ch.

A propos de la CEI

La Commission Electrotechnique Internationale (CEI) est la première organisation mondiale qui élabore et publie des Normes internationales pour tout ce qui a trait à l'électricité, à l'électronique et aux technologies apparentées.

A propos des publications CEI

Le contenu technique des publications de la CEI est constamment revu. Veuillez vous assurer que vous possédez l'édition la plus récente, un corrigendum ou amendement peut avoir été publié.

Liens utiles:

Recherche de publications CEI - www.iec.ch/searchpub

La recherche avancée vous permet de trouver des publications CEI en utilisant différents critères (numéro de référence, texte, comité d'études,...).

Elle donne aussi des informations sur les projets et les publications remplacées ou retirées.

Just Published CEI - webstore.iec.ch/justpublished

Restez informé sur les nouvelles publications de la CEI. Just Published détaille les nouvelles publications parues. Disponible en ligne et aussi une fois par mois par email.

Electropedia - www.electropedia.org

Le premier dictionnaire en ligne au monde de termes électroniques et électriques. Il contient plus de 30 000 termes et définitions en anglais et en français, ainsi que les termes équivalents dans les langues additionnelles. Egalement appelé Vocabulaire Electrotechnique International (VEI) en ligne.

Service Clients - webstore.iec.ch/csc

Si vous désirez nous donner des commentaires sur cette publication ou si vous avez des questions contactez-nous: csc@iec.ch.

INTERNATIONAL STANDARD

NORME INTERNATIONALE

**Household and similar electrical appliances – Safety –
Part 2-15: Particular requirements for appliances for heating liquids**

**Appareils électrodomestiques et analogues – Sécurité –
Partie 2-15: Exigences particulières pour les appareils de chauffage des liquides**

INTERNATIONAL
ELECTROTECHNICAL
COMMISSION

COMMISSION
ELECTROTECHNIQUE
INTERNATIONALE

PRICE CODE
CODE PRIX

U

CONTENTS

FOREWORD.....	3
INTRODUCTION.....	6
1 Scope.....	7
2 Normative references	8
3 Terms and definitions	8
4 General requirement.....	10
5 General conditions for the tests	10
6 Classification.....	10
7 Marking and instructions.....	10
8 Protection against access to live parts.....	12
9 Starting of motor-operated appliances	13
10 Power input and current.....	13
11 Heating.....	13
12 Void.....	15
13 Leakage current and electric strength at operating temperature.....	15
14 Transient overvoltages	15
15 Moisture resistance	15
16 Leakage current and electric strength.....	17
17 Overload protection of transformers and associated circuits	17
18 Endurance.....	17
19 Abnormal operation	17
20 Stability and mechanical hazards.....	19
21 Mechanical strength	20
22 Construction	20
23 Internal wiring.....	24
24 Components	24
25 Supply connection and external flexible cords	25
26 Terminals for external conductors.....	25
27 Provision for earthing	25
28 Screws and connections	25
29 Clearances, creepage distances and solid insulation	26
30 Resistance to heat and fire.....	26
31 Resistance to rusting.....	26
32 Radiation, toxicity and similar hazards.....	26
Annexes	28
Annex C (normative) Ageing test on motors	28
Bibliography.....	29

INTERNATIONAL ELECTROTECHNICAL COMMISSION

**HOUSEHOLD AND SIMILAR ELECTRICAL APPLIANCES –
SAFETY –****Part 2-15: Particular requirements
for appliances for heating liquids**

FOREWORD

- 1) The International Electrotechnical Commission (IEC) is a worldwide organization for standardization comprising all national electrotechnical committees (IEC National Committees). The object of IEC is to promote international co-operation on all questions concerning standardization in the electrical and electronic fields. To this end and in addition to other activities, IEC publishes International Standards, Technical Specifications, Technical Reports, Publicly Available Specifications (PAS) and Guides (hereafter referred to as "IEC Publication(s)"). Their preparation is entrusted to technical committees; any IEC National Committee interested in the subject dealt with may participate in this preparatory work. International, governmental and non-governmental organizations liaising with the IEC also participate in this preparation. IEC collaborates closely with the International Organization for Standardization (ISO) in accordance with conditions determined by agreement between the two organizations.
- 2) The formal decisions or agreements of IEC on technical matters express, as nearly as possible, an international consensus of opinion on the relevant subjects since each technical committee has representation from all interested IEC National Committees.
- 3) IEC Publications have the form of recommendations for international use and are accepted by IEC National Committees in that sense. While all reasonable efforts are made to ensure that the technical content of IEC Publications is accurate, IEC cannot be held responsible for the way in which they are used or for any misinterpretation by any end user.
- 4) In order to promote international uniformity, IEC National Committees undertake to apply IEC Publications transparently to the maximum extent possible in their national and regional publications. Any divergence between any IEC Publication and the corresponding national or regional publication shall be clearly indicated in the latter.
- 5) IEC itself does not provide any attestation of conformity. Independent certification bodies provide conformity assessment services and, in some areas, access to IEC marks of conformity. IEC is not responsible for any services carried out by independent certification bodies.
- 6) All users should ensure that they have the latest edition of this publication.
- 7) No liability shall attach to IEC or its directors, employees, servants or agents including individual experts and members of its technical committees and IEC National Committees for any personal injury, property damage or other damage of any nature whatsoever, whether direct or indirect, or for costs (including legal fees) and expenses arising out of the publication, use of, or reliance upon, this IEC Publication or any other IEC Publications.
- 8) Attention is drawn to the Normative references cited in this publication. Use of the referenced publications is indispensable for the correct application of this publication.
- 9) Attention is drawn to the possibility that some of the elements of this IEC Publication may be the subject of patent rights. IEC shall not be held responsible for identifying any or all such patent rights.

This part of International Standard IEC 60335 has been prepared by IEC technical committee 61: Safety of household and similar electrical appliances.

This sixth edition cancels and replaces the fifth edition published in 2002 including its Amendment 1 (2005) and its Amendment 2 (2008). It constitutes a technical revision.

The principal changes in this edition as compared with the fifth edition of IEC 60335-2-15 are as follows (minor changes are not listed):

- added requirements for soy milk makers;
- added requirements for dynamic pressure cookers;
- expanded requirements for cordless kettles to cover cordless appliances throughout document;

- reorganized 7.12 so that instructions related to generic types of appliances covered by this part are listed first;
- converted notes to normative (5.2, 7.12, 19.101, 22.7, 22.106, 24.1.5, 24.4, 25.101) text;
- deleted Note in 19.102.

The text of this standard is based on the following documents:

FDIS	Report on voting
61/4451/FDIS	61/4504/RVD

Full information on the voting for the approval of this standard can be found in the report on voting indicated in the above table.

This publication has been drafted in accordance with the ISO/IEC Directives, Part 2.

This part 2 is to be used in conjunction with the latest edition of IEC 60335-1 and its amendments. It was established on the basis of the fifth edition (2010) of that standard.

NOTE 1 When "Part 1" is mentioned in this standard, it refers to IEC 60335-1.

This part 2 supplements or modifies the corresponding clauses in IEC 60335-1, so as to convert that publication into the IEC standard: Safety requirements for appliances for heating liquids.

When a particular subclause of Part 1 is not mentioned in this part 2, that subclause applies as far as is reasonable. When this standard states "addition", "modification" or "replacement", the relevant text in Part 1 is to be adapted accordingly.

NOTE 2 The following numbering system is used:

- subclauses, tables and figures that are numbered starting from 101 are additional to those in Part 1;
- unless notes are in a new subclause or involve notes in Part 1, they are numbered starting from 101, including those in a replaced clause or subclause;
- additional annexes are lettered AA, BB, etc.

NOTE 3 The following print types are used:

- requirements: in roman type;
- *test specifications: in italic type;*
- notes: in small roman type.

Words in **bold** in the text are defined in Clause 3. When a definition concerns an adjective, the adjective and the associated noun are also in bold.

The committee has decided that the contents of this publication will remain unchanged until the stability date indicated on the IEC web site under "<http://webstore.iec.ch>" in the data related to the specific publication. At this date, the publication will be

- reconfirmed,
- withdrawn,
- replaced by a revised edition, or
- amended.

NOTE 4 The attention of National Committees is drawn to the fact that equipment manufacturers and testing organizations may need a transitional period following publication of a new, amended or revised IEC publication in which to make products in accordance with the new requirements and to equip themselves for conducting new or revised tests.

It is the recommendation of the committee that the content of this publication be adopted for implementation nationally not earlier than 12 months or later than 36 months from the date of publication.

A list of all parts of the IEC 60335 series, under the general title: *Household and similar electrical appliances – Safety*, can be found on the IEC website.

The following differences exist in the countries indicated below.

- 19.101: The test is not applicable (Japan).
- 25.8: A supply cord having a cross-sectional area of 0,75 mm² is not allowed for appliances having a rated current exceeding 6 A (Japan).
- 25.8: Longer supply cords are allowed (Japan).

INTRODUCTION

It has been assumed in the drafting of this International Standard that the execution of its provisions is entrusted to appropriately qualified and experienced persons.

This standard recognizes the internationally accepted level of protection against hazards such as electrical, mechanical, thermal, fire and radiation of appliances when operated as in normal use taking into account the manufacturer's instructions. It also covers abnormal situations that can be expected in practice and takes into account the way in which electromagnetic phenomena can affect the safe operation of appliances.

This standard takes into account the requirements of IEC 60364 as far as possible so that there is compatibility with the wiring rules when the appliance is connected to the supply mains. However, national wiring rules may differ.

If an appliance within the scope of this standard also incorporates functions that are covered by another part 2 of IEC 60335, the relevant part 2 is applied to each function separately, as far as is reasonable. If applicable, the influence of one function on the other is taken into account.

When a part 2 standard does not include additional requirements to cover hazards dealt with in Part 1, Part 1 applies.

NOTE 1 This means that the technical committees responsible for the part 2 standards have determined that it is not necessary to specify particular requirements for the appliance in question over and above the general requirements.

This standard is a product family standard dealing with the safety of appliances and takes precedence over horizontal and generic standards covering the same subject.

NOTE 2 Horizontal and generic standards covering a hazard are not applicable since they have been taken into consideration when developing the general and particular requirements for the IEC 60335 series of standards. For example, in the case of temperature requirements for surfaces on many appliances, generic standards, such as ISO 13732-1 for hot surfaces, are not applicable in addition to Part 1 or part 2 standards.

An appliance that complies with the text of this standard will not necessarily be considered to comply with the safety principles of the standard if, when examined and tested, it is found to have other features that impair the level of safety covered by these requirements.

An appliance employing materials or having forms of construction differing from those detailed in the requirements of this standard may be examined and tested according to the intent of the requirements and, if found to be substantially equivalent, may be considered to comply with the standard.

HOUSEHOLD AND SIMILAR ELECTRICAL APPLIANCES – SAFETY –

Part 2-15: Particular requirements for appliances for heating liquids

1 Scope

This clause of Part 1 is replaced by the following.

This International Standard deals with the safety of electrical appliances for heating liquids for household and similar purposes, their **rated voltage** being not more than 250 V.

NOTE 101 Some appliances can be used for heating food.

NOTE 102 Examples of appliances that are within the scope of this standard are

- coffee-makers;
- cooking pans;
- egg boilers;
- **feeding-bottle heaters;**
- kettles and other appliances for boiling water, having a **rated capacity** not exceeding 10 l;
- milk heaters;
- pressure cookers having a **rated cooking pressure** not exceeding 140 kPa and a **rated capacity** not exceeding 10 l;
- **rice cookers;**
- slow cookers;
- **steam cookers;**
- **soy milk makers;**
- tea maker;
- wash boilers;
- yoghurt makers.

Appliances intended for normal household and similar use and that may also be used by laymen in shops, in light industry and on farms, are within the scope of this standard.

NOTE 103 Examples of such appliances are

- glue pots with a water jacket;
- livestock feed boilers;
- sterilizers.

If the appliance is intended to be used professionally to process food for commercial consumption, the appliance is not considered to be for household and similar use only.

As far as is practicable, this standard deals with the common hazards presented by appliances that are encountered by all persons in and around the home. However, in general, it does not take into account

- persons (including children) whose
 - physical, sensory or mental capabilities; or
 - lack of experience and knowledgeprevents them from using the appliance safely without supervision or instruction;

- children playing with the appliance.

NOTE 104 Attention is drawn to the fact that

- for appliances intended to be used in vehicles or on board ships or aircraft, additional requirements may be necessary;
- in many countries, additional requirements are specified by the national health authorities, the national authorities responsible for the protection of labour, the national water supply authorities and similar authorities.

NOTE 105 This standard does not apply to

- frying pans and deep fat fryers (IEC 60335-2-13);
- storage water heaters (IEC 60335-2-21);
- instantaneous water heaters (IEC 60335-2-35);
- surface-cleaning appliances employing liquids or steam (IEC 60335-2-54);
- portable immersion heaters (IEC 60335-2-74);
- commercial dispensing appliances and vending machines (IEC 60335-2-75);
- appliances for medical purposes (IEC 60601);
- appliances intended exclusively for industrial purposes;
- appliances intended to be used in locations where special conditions prevail, such as the presence of a corrosive or explosive atmosphere (dust, vapour or gas);
- appliances for high-frequency heating;
- pressure sterilizers;
- humidifiers for household and similar use (IEC 60335-2-98).

NOTE 106 Attention is drawn to the fact that in many countries requirements for pressure vessels are applied to pressure cookers.

2 Normative references

This clause of Part 1 is applicable.

3 Terms and definitions

This clause of Part 1 is applicable except as follows.

3.1.9 *Replacement:* **normal operation**

operation of the appliance under the following conditions

3.1.9.101 Kettles, thermal pots, urns and other appliances for boiling water, coffee-makers, cooking pans, glue pots, milk heaters, slow cookers, sterilizers, wash boilers and yoghurt makers are operated with their container filled with the **rated capacity** of water, any lid being closed. The quantity of water in slow cookers is maintained above 50 % of their **rated capacity**.

Appliances with a heated surface intended to keep the liquid warm are operated with or without the container, whichever is the more unfavourable.

3.1.9.102 Egg boilers and **steam cookers** are operated with their containers filled with the maximum quantity of water specified in the instructions.

3.1.9.103 **Feeding-bottle heaters** are operated with a bottle of heat-resistant glass, round or hexagonal in shape, having a mass between 190 g and 200 g and a capacity of approximately 225 ml, unless a particular bottle is specified, in which case that bottle is used. The bottle is filled to approximately its **rated capacity** of water or 200 ml, whichever is less, and is placed in the **feeding-bottle heater**. The heater is filled with water to the level specified in the instructions or, in the absence of instructions, to the maximum level.

3.1.9.104 Livestock feed boilers are operated with the lid closed, the container being filled with half its **rated capacity** of water.

3.1.9.105 Pressure cookers are operated in accordance with the instructions but with the container filled with water to a depth of 25 mm.

3.1.9.106 Rice cookers are operated with the rice container filled with water to the level of maximum rated capacity. Water is added to maintain the level during boiling.

When operated in the keep-warm mode, the **rice cooker** is operated with the rice container empty.

3.1.9.107 Soy milk makers are operated with the container filled with soy beans in accordance with the instructions and water to the **rated capacity**.

3.101

rated capacity

capacity assigned to the appliance by the manufacturer

3.102

rated cooking pressure

pressure assigned to the appliance by the manufacturer

3.103

espresso coffee-maker

coffee-maker in which water is heated and forced through the ground coffee by steam pressure or by means of a pump

Note 1 to entry: **Espresso coffee-makers** may have an outlet for supplying steam or hot water.

3.104

feeding-bottle heater

appliance for heating prepared baby food in a feeding-bottle to a predetermined temperature, heat being transferred by means of water

3.105

pressure regulator

control that maintains the pressure at a particular value during normal use

3.106

pressure-relief device

control that limits the pressure under abnormal operating conditions

3.107

cordless kettle

kettle incorporating a heating element and which is connected to the supply only when placed on its associated stand

3.108

steam cooker

appliance in which food is heated by steam generated at atmospheric pressure

3.109

rice cooker

appliance for cooking rice that is placed in a detachable container, the container being placed within the appliance when cooking

Note 1 to entry: **Rice cookers** may have a keep warm function.

Note 2 to entry: **Rice cookers** may cook food other than rice.

3.110

induction rice cooker

rice cooker that heats the rice container by means of eddy currents

Note 1 to entry: The eddy currents are induced in the rice container or lid or rice container and lid by the electromagnetic field of a coil.

3.111

cordless appliance

appliance incorporating a heating element and which is connected to the supply only when placed on its associated stand

3.112

dynamic pressure cooker

pressure cooker which reduces the pressure by a dynamic action of an elastic part

3.113

soy milk maker

appliance with heating, pulverising and agitating functions that are intended to make soy milk

4 General requirement

This clause of Part 1 is applicable.

5 General conditions for the tests

This clause of Part 1 is applicable except as follows.

5.2 Addition:

If the test of 15.101 has to be carried out, three additional samples are required.

5.3 Addition:

The test of 19.101 is carried out after the other tests.

5.101 *Induction rice cookers are tested as motor-operated appliances.*

6 Classification

This clause of Part 1 is applicable except as follows.

6.2 Addition:

Wash boilers and livestock feed boilers shall be at least IPX3.

7 Marking and instructions

This clause of Part 1 is applicable except as follows.

7.1 Addition:

Appliances intended to be partially immersed in water for cleaning shall be marked with the maximum level of immersion and with the substance of the following:

Do not immerse beyond this level.

Kettles shall have a level mark or other means to indicate when they are filled to **rated capacity**, unless they cannot be filled beyond their **rated capacity**. This indication shall be visible when the kettle is in the filling position. If the level mark is not self-evident, there shall be a reference **to** this mark on the outside of the kettle which shall be visible when the kettle is in its normal position of use.

If the closed position of the lid of a pressure cooker is not obvious, this position shall be marked on the appliance.

Stands provided with **cordless appliances** shall be marked with

- the name, trademark or identification mark of the manufacturer or responsible vendor;
- the model or type reference.

Soy milk makers shall have a level mark or other means to indicate when they are filled to **rated capacity**, unless they cannot be filled beyond their **rated capacity**.

7.12 Addition:

The instructions for appliances shall include the substance of the following:

This appliance is intended to be used in household and similar applications such as:

- staff kitchen areas in shops, offices and other working environments;
- farm houses;
- by clients in hotels, motels and other residential type environments;
- bed and breakfast type environments.

If the manufacturer wants to limit the use of the appliance to less than the above, this must be clearly stated in the instructions.

The instructions for appliances incorporating an appliance inlet, and intended to be partially or fully immersed in water for cleaning, shall state that the connector must be removed before the appliance is cleaned and that the appliance inlet must be dried before the appliance is used again.

The instructions for appliances normally cleaned after use, and not intended to be immersed in water for cleaning, shall state that the appliance must not be immersed. This requirement normally applies to coffee-makers, cooking pans, milk heaters, pressure cookers, **steam cookers**, slow cookers, **soy milk makers** and yoghurt makers.

The instructions for appliances intended to be used with a connector incorporating a **thermostat** shall state that only the appropriate connector must be used.

Unless kettles are constructed so that a hazard cannot arise from boiling water being ejected, the instructions shall state that if the kettle is overfilled, boiling water may be ejected.

The instructions for kettles filled through a lid aperture situated below the handle shall include the substance of the following:

- **WARNING:** Do not remove the lid while the water is boiling.
- **CAUTION:** Position the lid so that steam is directed away from the handle.

The caution statement is not required if the lid can only be closed so that steam is directed away from the handle.

The instructions for **cordless appliances** shall state that the appliance is only to be used with the stand provided.

If the appliance and stand of **cordless appliances** can be lifted together by gripping the handle of the appliance, the instructions shall include the substance of the following:

CAUTION: Insure that the appliance is switched off before removing it from its stand.

The instructions for **feeding-bottle heaters** shall state

- that the food should not be heated for too long;
- how to check that the correct food temperature has not been exceeded.

The instructions for pressure cookers, other than **dynamic pressure cookers**, shall state that the ducts in the **pressure regulator** allowing the escape of steam should be checked regularly to ensure that they are not blocked.

The instructions for **pressure cookers** shall also give details of how to open the container safely and state that the container must not be opened until the pressure has decreased sufficiently.

The instructions for egg boilers provided with a pricking device shall contain the substance of the following:

CAUTION: Avoid injuries from the egg pricking device.

For **espresso coffee-makers** incorporating a pressurized reservoir filled by the user, the instructions shall contain information for the safe refilling of the water reservoir and the substance of the following:

The instructions for all appliances shall include:

- a warning to avoid spillage on the connector
- details on how to clean the surfaces in contact with food
- a warning of potential injury from misuse
- a statement that the heating element surface is subject to residual heat after use.

The instructions for **soy milk makers** shall also include a statement that care shall be taken when handling the sharp cutting blades, emptying the container and during cleaning.

The instruction for **soy milk makers** incorporating a switch necessary for compliance with 22.40 shall include the substance of the following:

Switch off the appliance and disconnect from supply before changing accessories or approaching parts that move in use.

8 Protection against access to live parts

This clause of Part 1 is applicable except as follows.

8.1.2 Addition:

NOTE 101 Connecting devices in stands of **cordless appliances** are not considered to be socket-outlets.

9 Starting of motor-operated appliances

This clause of Part 1 is not applicable.

10 Power input and current

This clause of Part 1 is applicable.

11 Heating

This clause of Part 1 is applicable except as follows.

11.2 Addition:

Portable appliances are tested away from the walls of the test corner.

11.3 Addition:

NOTE 101 If the magnetic field of an **induction rice cooker** unduly influences the results, the temperature rises can be determined using platinum resistances with twisted connecting wires or any equivalent means.

11.4 Addition:

*If the temperature rise limits are exceeded in appliances incorporating motors, transformers or **electronic circuits**, and if the power input is lower than the **rated power input**, the test is repeated with the appliance supplied at 1,06 times the **rated voltage**.*

11.6 Addition:

Combined appliances are operated as **heating appliances**.

11.7 Replacement:

Appliances are operated for the duration specified in 11.7.101 to 11.7.105.

11.7.101 *For kettles incorporating a **temperature limiter**, the **temperature limiter** is reset 1 min after it has operated or as soon as possible afterwards. The test is terminated after the **temperature limiter** has operated for the second time.*

*For kettles incorporating a **thermostat**, the test is terminated 15 min after the water has attained a temperature of 95 °C.*

For other kettles, the test is terminated 5 min after the water has attained a temperature of 95 °C.

11.7.102 *For cooking pans, egg boilers, **feeding-bottle heaters**, glue pots, livestock feed boilers, milk heaters, sterilizers, wash boilers and for appliances that boil water other than kettles, the test is terminated*

- *for appliances without a thermal control, 15 min after the water in the container has attained a temperature of 95 °C or the maximum temperature it can attain if this is lower;*
- *for **portable appliances** provided with a thermal control, 15 min after the thermal control has operated for the first time;*

- for **fixed appliances** provided with a thermal control, 30 min after the thermal control has operated for the first time;
- 1 min after a continuous or repetitive acoustic signal having intervals of less than 5 s has sounded;
- when steady conditions are established, for egg boilers having provision for keeping eggs warm, and appliances having a heated surface intended to keep liquid warm.

11.7.103 Slow cookers, **rice cookers**, **steam cookers** and yoghurt makers are operated until steady conditions are established. Slow cookers are prewarmed in the dry state if this instruction is given.

11.7.104 **Espresso coffee-makers** are operated in accordance with the instructions, the coffee filter being filled with the maximum quantity of coffee of the type specified. The brewing period is followed by a rest period of 1 min or the period stated in the instructions, if this is longer. The water container is refilled during the rest periods.

For **automatic espresso coffee makers** and **espresso coffee makers** provided with a coffee pot, the brewing period is the time necessary to produce the maximum quantity of coffee allowed by the timer or by the capacity of the coffee pot.

For **manual espresso coffee makers**, if the maximum quantity of coffee to be produced is not specified in the instructions, the brewing period is the time necessary to produce 100 ml of coffee for each cycle.

For **espresso coffee-makers** having an outlet for supplying steam or hot water, the brewing period is immediately followed by a period during which the steam or water is supplied for the time stated in the instructions or for the following periods, whichever is more unfavourable:

- for **espresso coffee-makers** having an outlet for supplying steam, 1 min;
- for **espresso coffee-makers** having an outlet for supplying hot water, the time necessary to produce 100 ml of water.

NOTE The steam is blown into a vessel containing cold water.

Espresso coffee-makers are operated until steady conditions are established.

Other coffee-makers are operated for the time necessary to make the maximum quantity of coffee stated in the instructions. The container is then refilled as quickly as possible and the coffee-maker operated again.

The procedure is repeated until steady conditions are established.

11.7.105 Pressure cookers are operated for 15 min after attaining the maximum cooking pressure.

11.7.106 **Soy milk makers** are operated for a complete operating cycle.

11.8 Addition:

When an appliance connector incorporates a **thermostat**, the temperature rise limit for the pins of the inlet does not apply.

The temperature rise limits of motors, transformers and components of **electronic circuits**, including parts directly influenced by them, may be exceeded when the appliance is operated at 1,15 times **rated power input**.

12 Void

13 Leakage current and electric strength at operating temperature

This clause of Part 1 is applicable.

14 Transient overvoltages

This clause of Part 1 is applicable.

15 Moisture resistance

This clause of Part 1 is applicable except as follows.

15.2 Addition:

The test is only carried out with the appliance connector in position.

In case of doubt, the spillage test is carried out with the appliance deviating from the normal position of use by an angle not exceeding 5°.

*Kettles that can be filled through the spout are also tested on a plane inclined at an angle of 20° to the horizontal, with the spout uppermost. The kettle is filled with water containing approximately 1 % NaCl to the maximum level, if this indication is visible from the filling position, otherwise until water spills from the kettle. A further quantity, equal to 15 % of the **rated capacity** of the kettle, is then added as quickly as possible.*

*Kettles are then filled to **rated capacity** with water. They are placed on a plane inclined at an angle of 20° to the horizontal with their spout facing up the slope of the inclined plane. Water shall not be discharged from the kettle.*

*For **cordless appliances**, the test with the appliance on the horizontal plane is carried out with the appliance both on and off its stand. The additional test for kettles that can be filled through the spout is carried out only with the **cordless kettle** off its stand, the kettle being replaced on its stand in order to carry out the electric strength test of 16.3.*

For coffee makers provided with a removable coffee pot, the liquid container is filled with maximum amount of water containing 1 % NaCl. The funnel is placed in position but without placing the coffee pot in position. The appliance is switched on and operated until the container is empty.

Modification:

For steam sterilizers, replace the penultimate paragraph of this subclause of Part 1 by the following:

Steam sterilizers are placed on a horizontal surface and 30 ml of water containing approximately 1 % NaCl is poured onto the top rim in the most unfavourable place. The solution is poured steadily through a tube having an inner diameter of 8 mm over a period of 2 s, the lower end of the tube being 200 mm above the appliance.

NOTE 101 A schematic representation of the test arrangement is shown in Figure 101.

*For **rice cookers**, the test specified in Part 1 shall be conducted with the rice container in place.*

15.101 Appliances intended to be partially or completely immersed in water for cleaning shall have adequate protection against the effects of immersion.

Compliance is checked by the following tests, which are carried out on three additional appliances.

*The appliances are operated under **normal operation** at 1,15 times **rated power input**, until the **thermostat** operates for the first time. Appliances without a **thermostat** are operated until steady conditions are established. The appliances are disconnected from the supply, any appliance connector being withdrawn. They are then completely immersed in water containing approximately 1 % NaCl and having a temperature between 10 °C and 25 °C, unless they are marked with the maximum level of immersion, in which case they are immersed 50 mm deeper than this level.*

After 1 h, the appliances are removed from the saline solution, dried and subjected to the leakage current test of 16.2.

NOTE Care is taken to ensure that all moisture is removed from the insulation around the pins of appliance inlets.

This test is carried out four more times, after which the appliances shall withstand the electric strength test of 16.3, the voltage being as specified in Table 4.

*The appliance having the highest leakage current after the fifth immersion is dismantled and inspection shall show that there is no trace of liquid on insulation that could result in a reduction of **clearances** and **creepage distances** below the values specified in Clause 29.*

*The remaining two appliances are operated under **normal operation** at 1,15 times **rated power input** for 240 h. After this period, the appliances are disconnected from the supply and immersed again for 1 h. They are then dried and subjected to the electric strength test of 16.3, the voltage being as specified in Table 4.*

*Inspection shall show that there is no trace of liquid on insulation that could result in a reduction of **clearances** and **creepage distances** below the values specified in Clause 29.*

15.102 The connecting devices of stands for **cordless appliances** shall not be affected by water.

Compliance is checked by the following test.

The stand is placed on a horizontal surface and 30 ml of water containing approximately 1 % NaCl is poured onto the connecting device. The solution is poured steadily through a tube having an inner diameter of 8 mm over a period of 2 s, the lower end of the tube being 200 mm above the connecting device.

NOTE A schematic representation of the test arrangement is shown in Figure 101.

*The stand shall then withstand the electric strength test of 16.3, the test voltage for **reinforced insulation** being 2 500 V.*

15.103 The interior of **rice cookers** shall not be affected by water.

Compliance is checked by the following test.

*The **rice cooker** is placed on a horizontal surface, with the rice container removed and 30 ml of water containing approximately 1 % NaCl is poured on to the centre of the bottom of the interior of the **rice cooker**. The saline solution is poured steadily through a tube having an inner diameter of 8 mm and a length of 30 mm, over a period of 2 s, the lower end of the tube being 200 mm above the bottom of the **rice cooker**.*

NOTE A schematic representation of the test arrangement is shown in Figure 101.

*The **rice cooker** shall then withstand the electric strength test of 16.3.*

16 Leakage current and electric strength

This clause of Part 1 is applicable.

17 Overload protection of transformers and associated circuits

This clause of Part 1 is applicable.

18 Endurance

This clause of Part 1 is not applicable.

19 Abnormal operation

This clause of Part 1 is applicable except as follows.

19.1 Addition:

Kettles are not subjected to the test of 19.2.

*Kettles are also subjected to the test of 19.101, unless the appliance incorporates a **non-self-resetting thermal cut-out** that is not resettable by the user, in order to comply with 19.4.*

*Kettles for which compliance with 19.101 relies on the operation of a **self-resetting thermal cut-out** are also subjected to the test of 19.102.*

19.2 Addition:

Appliances are placed as near as possible to the walls of the test corner. They are tested empty with lids open or closed whichever is more unfavourable.

***Induction rice cookers** are operated under the conditions of Clause 11 with the rice container empty.*

19.3 Addition:

*Kettles are operated empty at 1,15 times **rated power input**.*

The test is also carried out with the kettle filled with sufficient water to cover the heating element, or to a depth of 10 mm if the heating element is not positioned inside the container, the lid being open or closed, whichever is more unfavourable.

19.4 Addition:

For pressure cookers,

- *all pressure regulating devices are rendered inoperative; and*
- *in other than **dynamic pressure cookers**, all **protective devices** that vent steam and **intentionally weak parts** that vent steam are rendered inoperative; and*

- *in **dynamic pressure cookers**, all **protective devices**, other than **intentionally weak parts**, that vent steam are rendered inoperative.*

19.7 *Addition:*

***Espresso coffee-makers** incorporating a pump are operated for a period of 5 min.*

***Soy milk makers** are operated for one cycle of operation.*

19.13 *Addition:*

*During the test of 19.4, **protective devices** of pressure cookers other than **dynamic pressure cookers** shall operate before the pressure has reached 350 kPa.*

*During the test of 19.4, **protective devices** or **intentionally weak parts** of **dynamic pressure cookers** shall operate before the pressure has reached 250 kPa.*

*The temperature rise of the windings of **induction rice cookers** shall not exceed the values specified in 19.7.*

*The electric strength test of **induction rice cookers** is carried out immediately after switching off the appliance.*

19.101 *Kettles are placed on a plywood board having a thickness of approximately 20 mm. The **thermal cut out** that operates during the test of 19.4 and all thermal controls that operate during the test of Cause 11 are short circuited simultaneously and the kettle is operated empty at 0,85 times **rated power input** or 1,15 times **rated power input**, whichever is more unfavourable. If the kettle incorporates more than one **thermal cut-out** that could operate during the test of 19.4, they are short circuited in turn.*

During the test, any flames shall be kept within the enclosure of the kettle and the supporting surface shall not ignite.

*After the test, **live parts** shall not be accessible and the other requirements of 19.13 are not applicable.*

19.102 *Kettles incorporating two **self-resetting thermal cut-outs** are operated with one of the **thermal cut-outs** short circuited. The kettle is operated empty at 0,85 times **rated power input** or 1,15 times **rated power input**, whichever is more unfavourable.*

*Within 2 s of the other **thermal cut-out** operating, the kettle is filled with water having a temperature of 15 °C ± 5 °C. After 1 min, the kettle is emptied.*

The test is carried out 100 times.

19.103 *For appliances with detachable liquid containers, the automatic transfer of liquid from one container to another shall not give rise to an electrical hazard if they are incorrectly positioned.*

Compliance is checked by assembling the appliance with its receiving container incorrectly positioned or removed. The water discharge pipe is incorrectly positioned if this is more unfavourable. The appliance is operated as specified in Clause 11 but for one cycle only.

*The appliance shall then withstand the electric strength test of 16.3 and inspection shall show that there is no trace of water on insulation that could result in the reduction of **clearances** and **creepage distances** below the values specified in Clause 29.*

19.104 The overloading of a **soy milk maker** shall not result in a hazard.

Compliance is checked by the following test.

Soy milk makers are placed on a plywood board having a thickness of approximately 20 mm and operated under the conditions of clause 11 with the container filled with 2 times the maximum mass of the soy beans specified in the instructions and water to rated capacity.

During the test, any flames shall be kept within the enclosure and the supporting surface shall not ignite.

After the test, live parts shall not be accessible.

19.105 When a **soy milk maker** is disconnected from the supply accidentally during normal use, it shall not result in a hazard.

Compliance is checked by the following test.

Soy milk makers are placed on a plywood board having a thickness of approximately 20 mm and operated under the conditions of Clause 11. The appliance shall be disconnected from the supply at the most unfavourable time during the cycle. The **soy milk maker** is then restarted with a new cycle of operation without changing the load.

During the test, any flames shall be kept within the enclosure and the supporting surface shall not ignite.

After the test, live parts shall not be accessible.

20 Stability and mechanical hazards

This clause of Part 1 is applicable except as follows.

20.101 The container and cutting blades of **soy milk makers** shall have adequate mechanical strength.

Compliance is checked by the following test.

*The **soy milk maker** is supplied at **rated voltage** and is operated continuously with the container filled with dry soy beans to the rated capacity. The test is carried out as follows:*

- for appliances with accumulated working time of the motor during one cycle not exceeding 4 min, the test is conducted for the accumulated working time of the motor during one complete working cycle plus 1 min;*
- for appliances with accumulated working time of the motor during one cycle exceeding 4 min, the test is conducted for the accumulated working time of the motor during one complete working cycle.*

Care needs to be taken to ensure that the cutting blades are not jammed by the soy beans, and that they rotate continuously during the test.

After the test, the container and cutting blades shall not be broken; however, distorted and blunt edges are ignored.

20.102 The rotating parts of **soy milk makers** shall be secured so that they do not become loose during operation.

Compliance is checked by inspection and manual test.

Fastening of screws and nuts in a direction opposite to the direction of rotation of the rotating parts is considered to be a suitable means of securing the rotating parts.

20.103 The lid interlock, if any, of **soy milk makers** shall be constructed so that accidental operation of the appliance is prevented. Lid interlock switches shall be **biased-off switches**.

If there is an interlock between the lid and the main switch, the lid shall be locked when the switch is in the on position. When the lid is not correctly closed, the switch shall be locked in the off position.

Compliance is checked by inspection, by manual test and by applying test probe B of IEC 61032.

21 Mechanical strength

This clause of Part 1 is applicable except as follows.

21.1 Addition:

Breakage of glass parts is neglected provided that compliance with 8.1, 15.1 and 15.101 is not impaired.

22 Construction

This clause of Part 1 is applicable except as follows.

22.6 Addition:

Drain holes shall be at least 5 mm in diameter or 20 mm² in area with a width of at least 3 mm.

Compliance is also checked by measurement.

22.7 Addition:

Espresso coffee-makers are filled with water to their **rated capacity** and operated at **rated power input** with the coffee filter blocked and any valve for the supply of steam closed. The maximum pressure attained is measured. The appliance is then subjected to twice the measured pressure for 5 min.

*The overpressure may be supplied from an external source, care being taken to ensure that the **espresso coffee-maker** is at the normal temperature for brewing.*

If the valve for steam supply is linked to the switch used for starting the production of steam, this link is not to be disturbed while measuring the maximum pressure.

*The appliance shall not rupture, there shall be no leakage other than through a self-resetting **pressure-relief device** and the appliance shall be suitable for further use.*

Controls that limit the pressure are rendered inoperative and the appliance is operated again as described for determining the maximum pressure.

The appliance shall not explode or emit hazardous jets of steam. If an intentionally weak part ruptures, the test is repeated on a second appliance and shall be terminated in the same mode.

All **pressure regulators** and **pressure-relief devices** of pressure cookers except **dynamic pressure cookers** are rendered inoperative and the lid is closed. The pressure is gradually increased hydraulically to two times the operating pressure of the **pressure relief device** during the test of 19.4.

For **dynamic pressure cookers**, the pressure is gradually increased hydraulically to 50 kPa in excess of the operating pressure of the **pressure relief device** or **intentionally weak part** during the test of 19.4.

The container shall not rupture.

22.40 Addition:

For **soy milk makers**, any switch controlling the motor shall also disconnect electronic circuits, if their malfunction would impair compliance with this standard.

Compliance is checked by the tests of Clause 19.

22.101 Kettles shall be constructed so that the lid does not fall off when water is poured out.

Compliance is checked by the following test.

The kettle is filled to its **rated capacity** and the lid closed in accordance with the instructions. The kettle is supplied at **rated voltage** and operated until the water boils. Approximately 90 % of the water is poured from the kettle in the normal way. The lid shall not fall off and water shall only be emitted from the spout.

22.102 Kettles shall be constructed so that there are no sudden jets of steam or hot water likely to expose the user to a hazard when the appliance is used as in normal use.

NOTE Normal use takes into account the instructions concerning the position of the lid and the likely position of the user's hands when gripping the handle.

Compliance is checked by inspection during the test of Clause 11.

22.103 The appliance coupler of **cordless appliances** shall be constructed to withstand the stresses occurring during normal use.

Compliance is checked by the following test.

The two live pins of the appliance are connected together and an external resistive load is connected in series with the supply. The external load is such that the current is 1,1 times **rated current**.

The appliance is placed on its stand and withdrawn

- for **cordless kettles**, 10 000 times
- for **cordless coffee makers**, 10 000 times
- for other **cordless appliances**, 6 000 times

at a rate of approximately 10 times per minute. The test is continued without current flowing for a further 10 000 times for **cordless kettles** and **cordless coffee makers** and 6 000 times for other **cordless appliances**.

If a single stand is supplied with more than one **cordless appliance**, the test for each **cordless appliance** shall be carried out using the same stand.

After the test, the appliance shall be suitable for further use and compliance with 8.1, 16.3, 27.5 and Clause 29 shall not be impaired.

The test is carried out without current flowing if the connection contacts cannot make or break on load.

22.104 Portable appliances for boiling water that have a **rated capacity** exceeding 3 l, and which are liable to overturn, shall be constructed so that the rate of discharge is limited.

Compliance is checked by the following test, appliances incorporating an appliance inlet being fitted with a cord set.

*The appliance is filled with water to its **rated capacity** and the lid closed in accordance with the instructions. It is placed on a horizontal plane in any position of normal use but orientated to produce the most unfavourable result.*

The plane is slowly inclined to an angle of 25°. If the appliance overturns, it is left in this position for 10 s and then returned to its normal position. The quantity of water remaining is measured. The rate of discharge of water is determined from the formula:

$$D = \frac{60(C_1 - C_2)}{t}$$

where

D is the rate of discharge of water;

*C₁ is the **rated capacity** in litres;*

C₂ is the remaining quantity of water in litres;

t is the duration of the discharge in seconds, measured from the time the appliance overturns.

The rate of discharge of water shall not exceed 16 l/min.

NOTE Suitable means can be used to prevent the appliance from slipping on the inclined plane.

22.105 Fixed appliances for boiling water shall be constructed so that the container is always open to the atmosphere through an aperture of at least 5 mm in diameter, or 20 mm² in area with a width of at least 3 mm. The aperture shall be located so that it is unlikely to be obstructed in normal use.

If the appliance has provision for discharging steam or for water overflow, the discharge aperture shall be at the base of the appliance and shall discharge vertically downwards.

Compliance is checked by inspection and by measurement.

22.106 Espresso coffee-makers shall be constructed so that it is not possible to remove the coffee filter by a simple operation while there is a hazardous pressure within the container.

Compliance is checked by inspection and by manual test. This requirement is considered to be met if the coffee filter can only be removed after it has been rotated through an angle of at least 30°.

22.107 Pressure cookers shall incorporate a non-self-resetting pressure or temperature responsive **pressure-relief device**.

Compliance is checked by inspection.

22.108 Pressure cookers shall be constructed so that the lid cannot be removed while the pressure within the container is excessive. They shall incorporate a means to release the pressure to a value such that the lid can be removed without risk.

Compliance is checked by the following test.

*The pressure cooker is operated as specified in Clause 11 until the **pressure regulator** operates for the first time.*

The pressure cooker is then disconnected from the supply and the pressure allowed to decrease until the pressure is 4 kPa. A force of 100 N is applied to the most unfavourable point where the lid or its handle can be gripped. It shall not be possible to remove the lid.

The internal pressure is then gradually reduced, the force of 100 N being maintained. There shall be no hazardous displacement of the lid when it is released.

This test is not carried out on pressure cookers when the lid is secured by screw clamps or other devices that ensure that the pressure is automatically reduced in a controlled manner before the lid can be removed.

22.109 Pressure cookers shall be constructed so that the pressure in the container is not excessive when the lid is not closed or is incorrectly fitted.

Compliance is checked by the following test.

The pressure cooker is operated under the conditions of Clause 11 with the lid fitted in the most unfavourable position that allows the pressure cooker to operate.

The pressure in the container shall not exceed 4,0 kPa.

22.110 Feeding-bottle heaters shall emit a visible or audible signal to indicate that the heating period is terminated.

Compliance is checked by inspection during the test of Clause 11.

22.111 Espresso coffee-makers, incorporating a pressurized reservoir filled by the user, shall be constructed so that there is no spillage of water or sudden jets of steam or hot water likely to expose the user to a hazard when the appliance is used in accordance with the instructions.

When removing the filling cap of the pressurized reservoir, before the cap is removed completely, the pressure shall be relieved in a controlled manner in order to avoid the emission of jets of steam or hot water that are likely to expose the user to a hazard.

Compliance is checked by inspection during the test of Clause 11 and by removing the filling cap at the end of the test.

22.112 Soy milk makers shall be constructed so that steam or hot water are not ejected which may expose the user to a hazard.

Compliance is checked by inspection.

22.113 Appliances with moving mechanical parts shall be constructed so that lubricants are prevented from polluting food compartments.

Compliance is checked by inspection.

22.114 Appliances shall be constructed so that food or liquids are prevented from penetrating into places that could cause electrical or mechanical faults.

Compliance is checked by inspection.

23 Internal wiring

This clause of Part 1 is applicable.

24 Components

This clause of Part 1 is applicable except as follows.

24.1.3 Addition:

*Switches incorporated in **espresso coffee-makers** for initiating brewing or steaming are subjected to 10 000 cycles of operation.*

*Switches incorporated in **dynamic pressure cookers** for controlling heaters are subjected to 50 000 cycles of operation and are tested under the conditions of Clause 11 with the appliance supplied at **rated voltage**.*

24.1.4 Addition:

***Self-resetting thermal cut-outs** required for compliance with the test of 19.101 are subjected to 3 000 cycles of operation.*

24.1.5 Addition:

*For appliance couplers incorporating **thermostats**, **thermal cut-outs** or fuses in the connectors, IEC 60320-1 is applicable except that*

- the earthing contact of the connector is allowed to be accessible, provided that this contact is not likely to be gripped during insertion or withdrawal of the connector;*
- the temperature required for the test of Clause 18 is that measured on the pins of the appliance inlet during the test of Clause 11 of this standard;*
- the breaking-capacity test of Clause 19 is carried out using the inlet of the appliance;*
- the temperature rise of current-carrying parts specified in Clause 21 is not determined.*

Thermal controls are not allowed in connectors complying with the standard sheets of IEC 60320-1.

24.4 Addition:

This requirement is not applicable to the connection between the appliance and the stand of **cordless appliances**.

24.101 Devices incorporated in appliances, other than kettles, for compliance with 19.4, shall be non-self-resetting. However, **self-resetting thermal cut-outs** are allowed for **fixed water boilers** if they have been subjected to 10 000 cycles of operation.

Compliance is checked by inspection and during the test of 19.4.

25 Supply connection and external flexible cords

This clause of Part 1 is applicable except as follows.

25.1 Addition:

Appliances incorporating an appliance inlet, other than those standardized in IEC 60320-1, shall be supplied with a cord set.

25.5 Addition:

Type Z attachment is allowed for egg boilers, **feeding-bottle heaters**, steam sterilizers, yoghurt makers and stands of **cordless appliances**.

25.7 Addition:

The **supply cord** of livestock feed boilers shall be polychloroprene sheathed.

25.8 Addition:

Portable appliances having a **rated current** up to 10 A may incorporate a **supply cord** having a nominal cross-sectional area of 0,75 mm², if the length is less than 2 m.

25.22 Addition:

Soy milk maker inlets shall be located so that pollution by soy milk is unlikely to occur during normal use.

Compliance is checked by inspection.

25.101 Supply cords of kettles shall not be longer than 75 cm, unless they are helically coiled.

Compliance is checked by measurement.

*If a **cordless kettle** has a cord storage facility, the length of the cord is measured after storing as much of the cord as possible.*

The length of the cord is measured between the plug and the point where the cord or cord guard enters the appliance.

26 Terminals for external conductors

This clause of Part 1 is applicable.

27 Provision for earthing

This clause of Part 1 is applicable.

28 Screws and connections

This clause of Part 1 is applicable.

29 Clearances, creepage distances and solid insulation

This clause of Part 1 is applicable except as follows.

29.2 Addition:

The microenvironment is pollution degree 3 if the insulation can be polluted by condensation from steam produced during normal use of the appliance.

30 Resistance to heat and fire

This clause of Part 1 is applicable except as follows.

30.1 Addition:

*For coffee-makers, egg boilers, kettles and **steam cookers**, the temperature rises occurring during the tests of 19.4, 19.5 and 19.101 are not taken into account.*

30.2 Addition:

For water distillers, appliances incorporating a delayed start timer and appliances intended to maintain liquid or food at a particular temperature, 30.2.3 is applicable. For other appliances, 30.2.2 is applicable.

31 Resistance to rusting

This clause of Part 1 is applicable.

32 Radiation, toxicity and similar hazards

This clause of Part 1 is applicable.

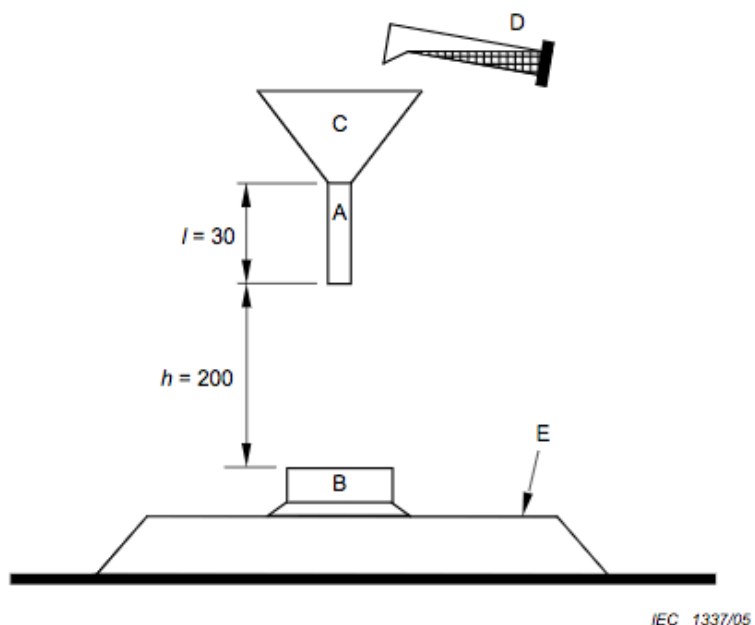

Dimensions in millimetres

Key

- A funnel tube with inner diameter of 8 mm
- B item under test
- C funnel
- D container with 30 ml of saline solution
- E horizontal surface

Figure 101 – Schematic representation of the 30 ml spillage test

Annexes

The annexes of Part 1 are applicable except as follows.

Annex C (normative)

Ageing test on motors

Modification:

The value of p in Table C.1 is 2 000.